

Original operating instructions

Oskar^o 08

As of 2023-11

INFORMATION

These operating instructions are part of the technical documentation for the device in accordance with:

- Directive 2014/35/EU of the European Parliament and of the Council of 26 February 2014 on the harmonisation of the laws of Member States relating to the making available on the market of electrical equipment designed for use within certain voltage limits
- Directive 2014/68/EU of the European Parliament and of the Council of 15 May 2014 on the harmonisation of the laws of Member States relating to the making available on the market of pressure equipment

These operating instructions are intended for the operator, who must hand them over to the personnel who come into contact with the device. The operator must ensure that the information contained in the operating instructions and the accompanying documents has been read and understood.

NOTE: If in any doubt, consult the operating instructions, which must be kept in a known and easily accessible place.

The manufacturer accepts no liability for damage to persons, animals or property, or to the device itself, resulting from improper use, failure to observe or insufficient observance of the safety criteria contained in these operating instructions, or from modification of the device or the use of unsuitable spare parts. The copyright for these operating instructions is held exclusively by the company:

ratiotherm

Smart Energy Systems

ratiotherm GmbH & Co. KG
Wellheimer Straße 34
91795 Dollnstein Germany

or its legal successor. The content of this operating manual is the intellectual property of ratiotherm GmbH & Co. KG. ratiotherm GmbH & Co. KG expressly reserves the property rights and copyright to the information contained in the operating manual. Reprinting and reproduction, even in part, are only permitted with the written consent of ratiotherm GmbH & Co. KG.

Status: 07.11.2022

TABLE OF CONTENTS

1	Information about the document	5
11	Safety and warning notices	5
12	Safety symbols	5
2	Identification and notices	7
21	Product data	7
22	Intended use	7
23	Target groups	7
24	Incorrect use	8
25	Warranty, liability, guidelines, standards and laws	9
3	Safety instructions	10
31	General safety instructions	10
32	Additional instructions	10
33	Residual risk	11
4	Structure and function	11
41	Connection heights	11
42	Technical data	12
43	Distribution cabinet dimensions	12
44	Dimensions 500 litres	13
45	Dimensions 750 litres	14
46	Dimensions 1,000 litres	15
47	Storage tank insulation	16
5	Transport, assembly and installation	17
51	Scope of delivery	17
52	Accessories	18
53	Assembly	19
6	Hydraulics	22
61	Storage tank charging hydraulics	22
62	Requirements for the system water	23
63	Hydraulic diagram	24
64	Hydraulic module	25
65	Hydraulic module / assemblies Maximum configuration	26
66	Drinking water station TWST	27
67	Circulation pump	28
68	Heat meter retrofit	29
69	Solar station 6-16	30
7	Central control unit	32
71	Safety regulations	32
72	Sensor immersion sleeve	33
73	Turbine flow sensor	34
74	Sensor	36
75	Technical data	38
76	Installation/removal of the controller	40
77	Input assignment	42
78	Output assignment	43
79	Input and output assignment RSM 610	44
7.10	Component wiring	45

INFORMATION

8.	Controller operation	47
8.1	Controller configuration	47
8.2	Times and setpoints	51
8.3	Inputs	53
8.4	Outputs	54
8.5	Maintenance	55
8.6	Service	56
8.7	Summer/winter operation service	58
8.8	Screed - Heating	59
8.9	Charging pumps	60
8.10	Solar thermal	61
8.11	Heat generation	62
9.	Data management	63
9.1	Overview window	63
9.2	Function data	64
9.3	Basic settings	66
10.	Controller accessories	67
10.1	C.M.I installation	67
10.2	C.M.I online connection	68
10.3	WNA online connection	70
11.	Problem solving	71
11.1	Problem solutions	71
12.	Appendix	73
12.1	Wilo Para STG 15/8-75 pump	73
12.2	Control modes and functions	74
12.3	Emergency operation of the pump	76
12.4	VRG 138 electric mixer	76
13.	Maintenance	77
14.	Decommissioning	78
14.1	Temporary decommissioning	78
14.2	Final decommissioning and disposal	78
15.	EC Declaration of Conformity	79

1. INFORMATION ABOUT THE DOCUMENT

The following notes serve as a guide through the entire documentation. Other documents are also valid in conjunction with these operating instructions. These operating instructions for specialist tradesmen are an integral part of the ratiotherm Oskar° 08 stratified storage tank. The ratiotherm Oskar° 08 stratified storage tank must not be operated without these operating instructions.

The operating instructions must be made available to the operator and the specialist installer for information at all times. If the ratiotherm Oskar° 08 stratified storage tank is sold, the instructions must also be supplied. We accept no liability for damage caused by failure to observe these instructions.

1.1 SAFETY AND WARNING NOTICES

Signal words and colours

The following signal words are based on DIN ISO 3864-2 and are used in this documentation. The safety colours have been adopted from the ISO 3864-1 standard. The design complies with DIN EN 82079-1 and ANSI Z 535.4.







Signal word	Explanation
DANGER	Indicates a hazardous situation which, if not avoided, will result in death or serious injury.
WARNING	Indicates a hazardous situation which, if not avoided, could result in death or serious injury.
CAUTION	Indicates a hazardous situation which, if not avoided, could result in minor injury or property damage.
NOTE	Indicates operating instructions and cross-references. A note indicates the risk of property damage or risk of injury.





1.2 SAFETY SIGNS

1.2.1 OTHER SYMBOLS ACCORDING TO DIN ISO 7010



Some of the following special safety signs according to DIN EN ISO 7010 and DIN ISO 3864 are used at the relevant points in this operating manual and, depending on the combination of signal word and graphic symbol, require special attention. Please note the distinction between:

- Mandatory signs – prescribe an action (e.g. use eye protection).
- Warning signs – depict a source of danger and supplement a warning notice.
- Prohibition signs – prohibit certain actions.



Symbol	Explanation	Symbol	Explanation
	General warning sign		Warning of flammable substances
	Warning of electrical voltage		General prohibition sign
	Warning of hot surfaces		No entry

Symbol	Explanation	Symbol	Explanation
	Follow instructions		General command sign
	Disconnect before maintenance or repair		Use hand protection

1.2.2 OTHER SIGNS ACCORDING TO DIN ISO 7000

Symbol	Explanation	Symbol	Explanation
	Observe the operating manual (instructions for use)		Service indicator, Refer to the operating manual (instructions for use)
	Instructions for use/operating instructions (operating manual)		

1.2.3 OTHER SYMBOLS

Symbol	Explanation	Symbol	Explanation
	Recycling		Dispose of packaging material in accordance with regulations

2. IDENTIFICATION AND NOTES

2.1 PRODUCT

Device designation: Stratified storage
 tank type: Oskar° 08
 Year of manufacture: See type plate
 Country of origin: Germany

2.2 INTENDED USE

The device, Oskar 08, is intended for use in storing heat. Any other or extended use of the device is considered improper and therefore inappropriate. In this case, the safety and protective functions of the device may be impaired. The company ratiotherm GmbH & Co. KG is not liable for any damage resulting from this. Proper use also includes:



- Compliance with all instructions in this operating manual,
- Observing all warnings and
- Compliance with the inspection and maintenance conditions.

The device, Oskar 08, is built according to the state of the art and recognised safety regulations. The device is intended exclusively for domestic and/or commercial use for the storage of hot water and service water. Improper or unintended use may result in danger to the life and limb of the user or third parties. In addition, damage to the device and other property may occur. The device, Oskar 08, is not intended for use by persons (including children) with limited physical, sensory or mental abilities, or persons with insufficient experience and/or knowledge. The risk is borne solely by the operator and user.



2.3 TARGET GROUPS

For safety reasons, the design of the device does not permit its use by persons with disabilities (e.g. visual impairments). 
DANGER! Only perform tasks for which you are authorised.

2.3.1 TARGET GROUP MATRIX

Tasks	Operators and users	Specialist personnel
Transport/storage		X
Assembly/installation		X
Commissioning/adjustment		X
Automatic operation (control)	X	X
Set-up/conversion/technical modification		X
Maintenance/inspections/repairs		X
Cleaning	X	X
Troubleshooting and fault rectification		X
Decommissioning/dismantling/disposal		X

2.3.2 TARGET GROUP DEFINITION

Operators and users

A person who has purchased the device for use in an existing system for direct heating support and hot water preparation. The person must have knowledge of the necessary protective devices and protective measures.

Qualification of operators and users:

- Of legal age and physically/mentally fit to perform work on the device.
- Knowledge of how to operate the product, imparted by qualified personnel and the operating instructions.



Specialist personnel

A person from a qualified specialist company for heating and hot water system knowledge and experience through professional training. The person must work assigned to them (e.g. instruction of personnel, switching on, program situations).

Qualification of qualified personnel:

- Of legal age and physically/mentally capable of performing work on the device.
- Knowledge: several years of experience working on heating systems and hot water preparation

2.4 MISUSE

2.4.1 REASONABLY FORESEEABLE MISUSE

Reasonably foreseeable misuse that poses a risk to personnel, third parties or the device applies to all operating modes:

- Using the device contrary to its intended use.
- Supplying components that are not certified by the manufacturer.
- Operating the device outside its physical operating limits.
- Modifying the control software without prior consultation with ratiotherm GmbH & Co. KG.
- Modifications to the device as well as additions and conversions without prior consultation with ratiotherm GmbH & Co. KG.
- Operating the device contrary to the provisions of the risk assessment.
- Bypassing or deactivating protective and safety devices.
- Operating the device with obvious faults.
- Operation of the device by persons (including children) with limited physical, sensory or mental abilities.



DANGER

Unauthorised modifications to the device

Unauthorised modifications pose a risk of death or injury.

Do not make any unauthorised modifications to the device without the prior consent of ratiotherm GmbH & Co. KG.

2.4.2 UNFORESEEABLE MISUSE/ABUSE

Unforeseeable misuse may occur due to:

- Disasters,
- the impact of foreign objects and/or
- force majeure.

2.5 WARRANTY, LIABILITY, GUIDELINES, STANDARDS AND LAWS

The "General Terms and Conditions of Sale and Delivery" of ratiotherm GmbH & Co. KG apply in principle. The "General Terms and Conditions of Sale and Delivery" have been available to the operator since the conclusion of the contract at the latest. Warranty and liability claims for personal injury and property damage are excluded if the damage is attributable to one or more of the following causes:

- Improper use of the device,
- Improper handling of the device,
- Operation of the device with defective protective devices,
- Failure to observe the safety and warning instructions in the operating manual,
- Unauthorised structural modifications to the device,
- Inadequate implementation of the specified maintenance measures, and
- disasters involving foreign objects or force majeure.

The operating instructions must be read before handling the device. The operating instructions familiarise personnel with the handling of the device and provide information on all phases of the device's life cycle.

The operating instructions must be accessible to personnel at all times. The safety and warning instructions in the operating instructions and on the device must be observed and complied with. If you have any further questions that go beyond the scope of these operating instructions, please contact ratiotherm GmbH & Co. KG.

The following guidelines, standards and laws must be observed when using the device in Germany:

- VDE and EVU regulations and provisions (in particular VDE 0100)
- Regulations and provisions of local utility companies
- DVGW worksheet W 382 "Installation and operation of pressure reducers in drinking water consumption systems"
- DIN 1988 – TRWI Technical rules for drinking water installations
- DIN 4753 – Water heating systems for drinking and service water
- DIN 8947 – Ready-to-connect heat pumps for water heating with electrically driven compressors
- Accident prevention regulations VGB 20 Accident prevention regulations "Refrigeration systems" with implementation instructions
- Energy Saving Ordinance EnEV – Ordinance on energy-saving thermal insulation and energy-saving system technology in buildings from 2009



NOTE

Guidelines, standards and laws

Additional local guidelines, standards and laws, e.g. building regulations, may apply. **As a general rule, the applicable legal guidelines, standards and laws in the respective country must be observed.**

3. SAFETY INSTRUCTIONS

 **DANGER!** Read and observe the operating instructions before working on and with the device.

Despite all precautions taken, there may still be some residual risks that are not immediately apparent. You can reduce the existing residual risks by observing and complying with the general safety instructions and warnings as well as the intended use.

3.1 GENERAL SAFETY INSTRUCTIONS

Observe the following general safety instructions:

- The volume of water increases during the heating process. Therefore, never close the blow-off pipe of the safety valve.
- Please note that hot water may escape from the blow-off pipe.
- If there are leaks in the area of the appliance, switch off the appliance and shut off the connection to the rest of the heating system. The leaks must then be repaired immediately.
- Do not use the following products to prevent corrosion on the device: sprays, solvents, chlorinated cleaning agents, paints, adhesives, etc.
- Components that have not been tested with the device may cause damage to the device or impair its functions. Only use original spare parts and original wear parts.
- Only allow qualified personnel to carry out the assembly/installation/commissioning/adjustment of the device.
- Observe the existing regulations, rules and guidelines as well as the local installation requirements.
- To avoid injuries of any kind, the general accident prevention regulations must be observed under all circumstances and appropriate personal protective equipment must be used.
- Technical modifications to the system are not permitted. This also applies to the retrofitting of safety devices and welding on load-bearing parts.
Safety devices must not be taken out of service. Only original spare parts and original accessories from the manufacturer may be used.

3.2 ADDITIONAL INFORMATION

Local accident prevention regulations apply to all work on the device. Please also observe the

- Applicable binding regulations on accident prevention,
- Recognised technical rules for safe and professional work,
- Existing regulations on environmental protection and
- Other applicable regulations.
- The outlet temperature at the hot water taps can be up to 60 °C. Carefully check the water temperature at the hot water taps before placing your hands completely under the water jet.
- Do not make any changes to the components:
 - To the stratified storage tank and the water and electricity pipes;
 - To the safety valve;
 - Structural conditions that may affect the operational safety of the device;
 - Structural conditions in the vicinity of the device, insofar as these may affect the operational safety of the device.

3.3 RESIDUAL RISK



WARNING

Measures/work carried out by unauthorised/unqualified personnel

Measures/work carried out on the device and/or its components and connections by unauthorised/unqualified personnel pose a serious risk of injury.



In the event of malfunctions, only allow qualified personnel to carry out measures/work on the device and/or its components and connections.



WARNING

Damaged insulation

Damaged insulation poses a serious risk of burns on hot and/or cold surfaces.



Protect yourself with suitable PPE (e.g. heat- and cold-resistant protective gloves).

Allow hot or cold surfaces to cool down or warm up before working on them. Replace damaged insulation.



WARNING

Ignition sources in the danger zone

Ignition sources in the danger zone can cause flammable substances to ignite and/or explode.

Keep ignition sources away from the danger zone.

4. STRUCTURE AND FUNCTION

4.1 CONNECTION HEIGHTS

Position heights of the connections from the lower edge of the storage tank feet					
Storage tank capacity		500 l	750 l	1,000 l	Unit
No. 1	Consumer (HT) RL:	707	704	704	mm
No. 2	Consumer (HT) VL:	1,660	1,657	1,989	mm
No. 3	Heat generator (NT) RL, consumer (NT) RL:	467	464	464	mm
No. 4	Heat generator (NT) VL, Consumer (NT) VL:	1,001	1,104	1,504	mm
No. 5	Heat generator (HT) RL:	991	1,094	1,494	mm
No. 6	Heat generator (HT) VL:	567	1,564	1,879	mm
No. 7	Solar RL:	1,307	1,304	1,584	mm
No. 8	Solar RL, heat generator (NT) RL:	200	180	200	mm

Sensor position heights from top edge of immersion tube sleeve					
Storage capacity		500 l	750 l	1,000 l	Unit
S2	Top storage tank load:	200	200	200	mm
S3	Storage tank charge WW (off):	540	450	450	mm
S4	Storage heating charge (on):	800	810	810	mm
S5	Bottom storage load:	1,500	1,500	1,880	mm

4.2 TECHNICAL DATA

Type Oskar° -08/1.5/...	500 l	750 l	1,000 l	Unit
Actual volume approx.:	496	720	920	litres
Volume flow:	1,500	1,500	1,500	l/h
Total height without insulation:	1,718	1,735	2,115	mm
Total height with insulation:	1,838	1,855	2,235	mm
Diameter without insulation:	650	790	790	mm
Diameter with insulation:	890	1,033	1,030	mm
Length of storage tank incl. connection piece:	774	915	915	mm
Weight without insulation approx.:	120	140	155	kg
Maximum tipping dimensions:	1,840	1,870	2,230	mm
Dimensional tolerances:	± 10	± 10	± 10	mm
Maximum operating pressure:	3	3	3	bat
Maximum operating temperature:	95	95	95	°C
Pressure loss Oskar°:	20	20	20	mbar
Pressure loss Oskar°:	0.2	0.2	0.2	mWS
Standby heat loss DIN:	1.75	1.92	2.27	kWh/d
Vent pipe at top:	1/2	1/2	1/2	RIG
Front storage connections:	8 x DN 25			
Tank material:	St 37-2 / S235JR / P265GH			
Paint finish:	Black anti-rust paint on the outside / untreated on the inside			
Dimensions of the hydraulic module:	700 x 1861 x 193			WxHxD

4.3 DIMENSIONS OF DISTRIBUTION CABINET

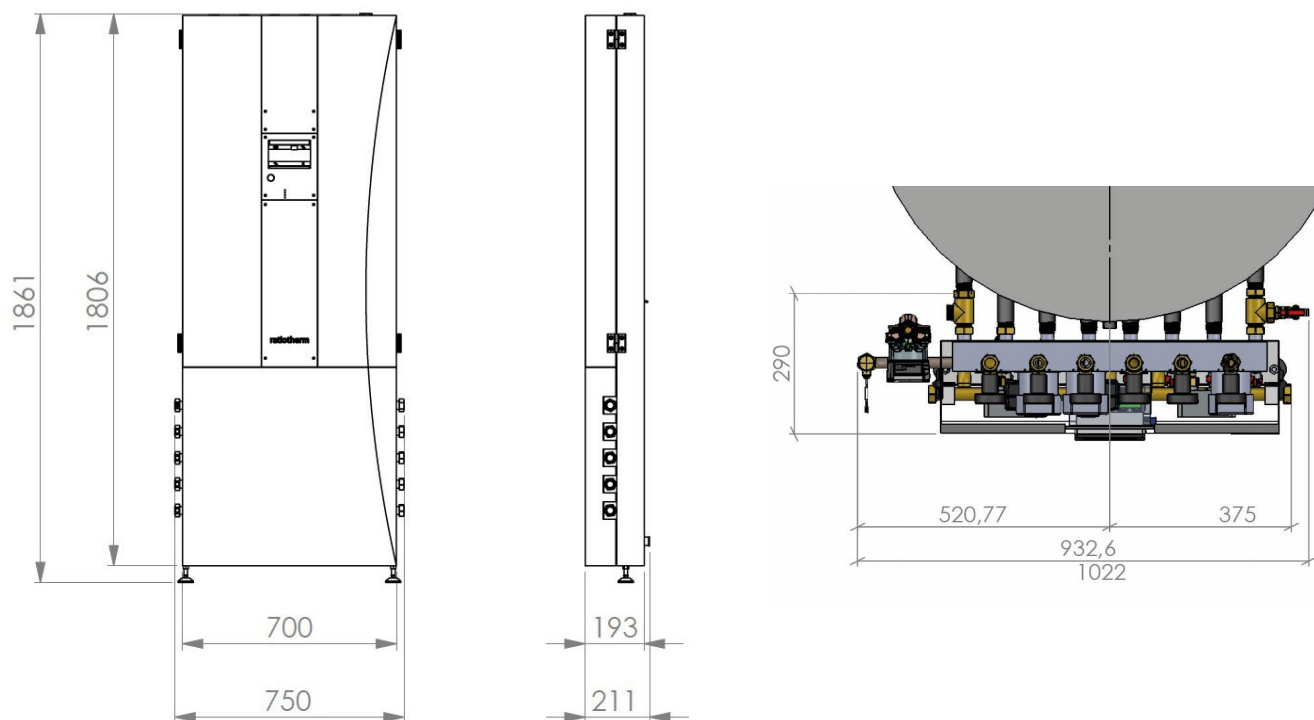

4.6 DIMENSIONS 1,000 LITRES

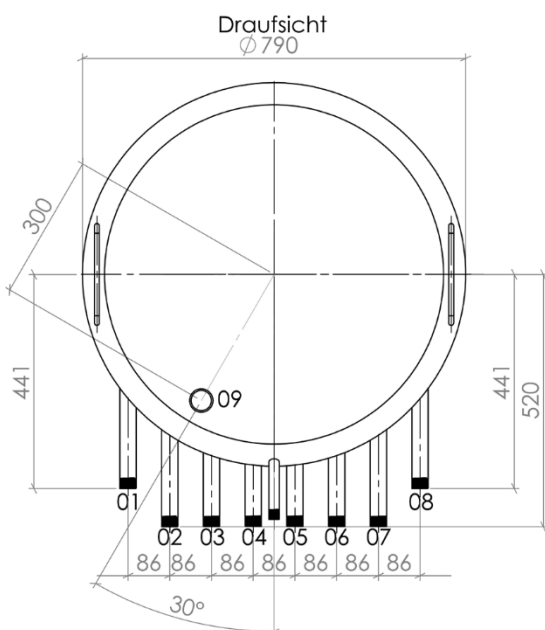
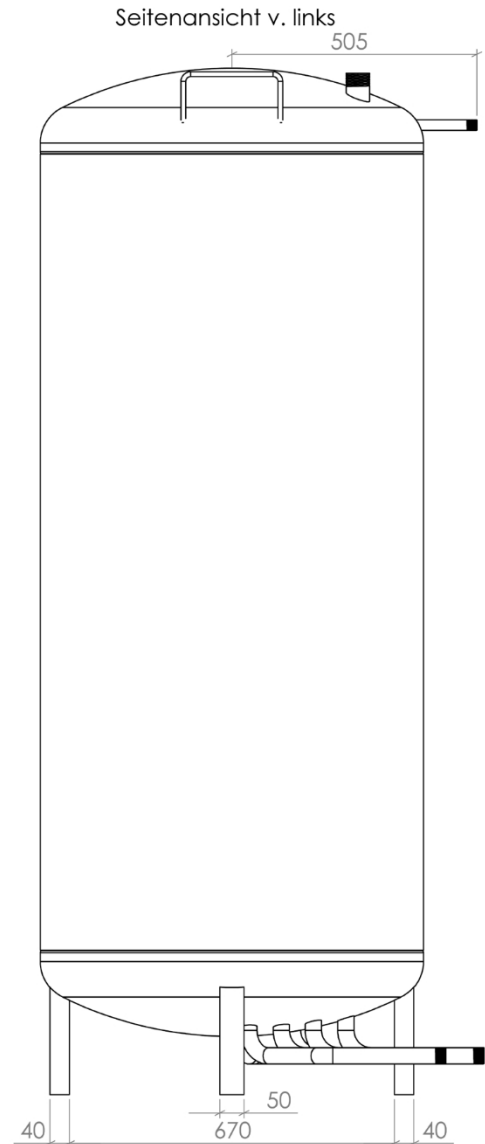
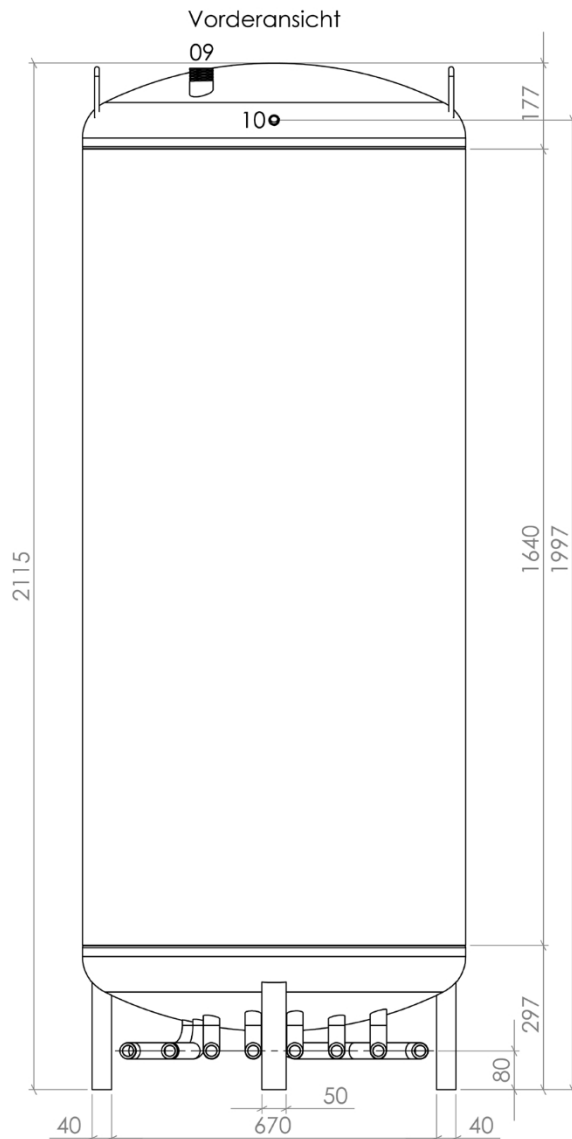

Isometrie Maßstab: 1:20

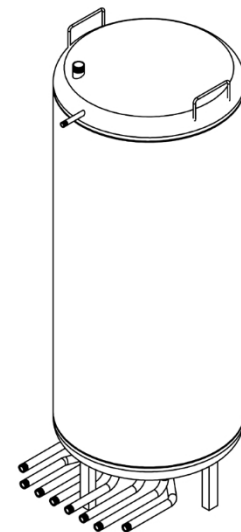

4.7 STORAGE TANK INSULATION

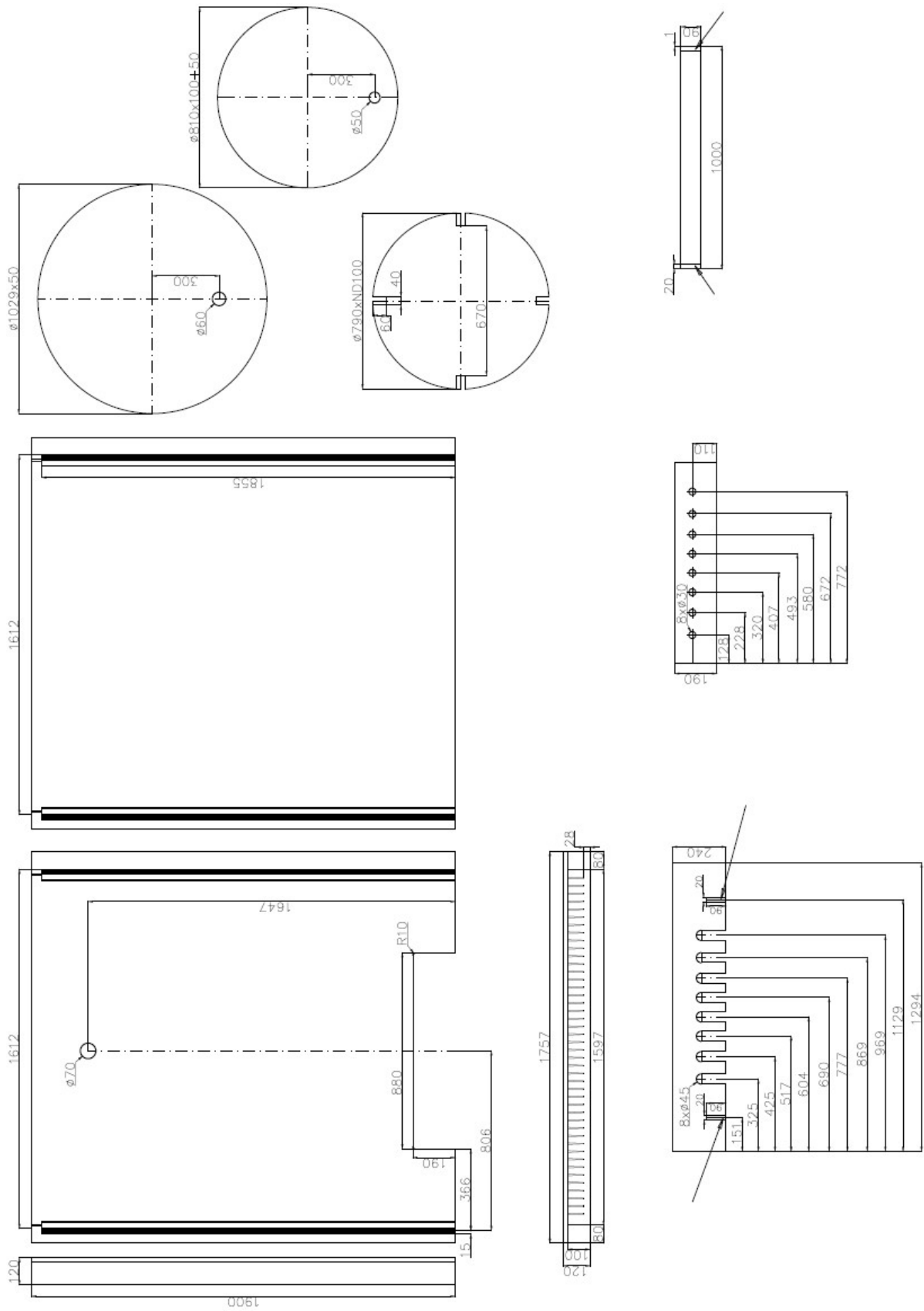

5. TRANSPORT, ASSEMBLY AND INSTALLATION

5.1 SCOPE OF DELIVERY

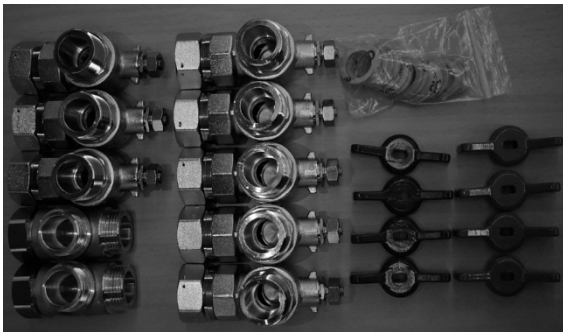

Storage tank connection set

2x RG T-piece, 1" x 1" ÜWM
8x corner ball valve 1" female thread x 1" male thread
4x red handles, 4x blue handles, seals 1x cap
3/4" (if no circulation)

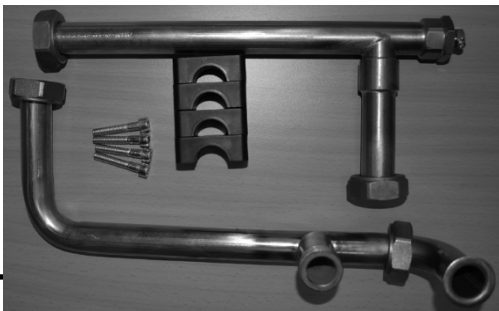

Hot and cold water connection set

1x straight pipe section for hot water connection
1x curved pipe piece for cold water connection with closed connection
circulation
4x plastic clamps with screws for securing the pipes in the hydraulic module



PT1000 temperature sensor for heat generator (boiler sensor), optional

1x pipe contact sensor with contact strap for
heat generators without immersion sleeve
1x pipe insertion sensor
for heat generators with immersion sleeve



Clip for heating circuit contact sensor

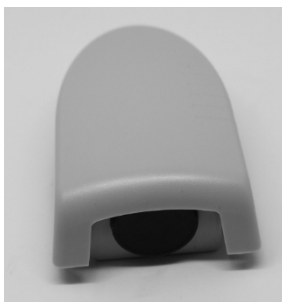

PT1000 outdoor sensor

5.2 ACCESSORIES



Drain and expansion vessel fitting

1x DN25 ball valve with flat seal (RG) 905003

1x connection bracket G 1" male thread x G 1" male thread x G 1/2" female thread

1x RG red piece, 1" male thread x 3/4" female thread (fd.) WIP

1x Optiflex ball valve 3/8", drain valve 1x brass cap, 1", seal kit



Connection set, side (left and/or right)

3x ball valve 1" male thread to 1" male thread, blue, wing handle 626

2x ball valve 1" male thread to 1" male thread, red, wing handle 626

3x drain valve with rotatable outlet 1/2" male thread 2x RG plug 1" without rim, PURAFIT



Mounting set for 1,000 litre storage tank

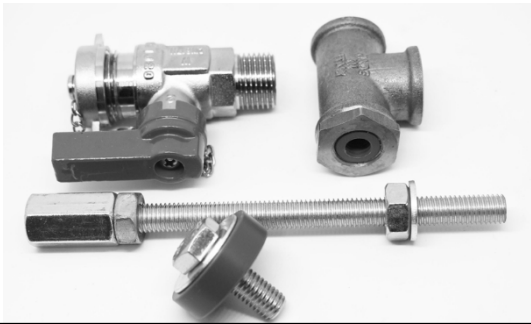

Mounting set for 500 and 750 litre storage tanks

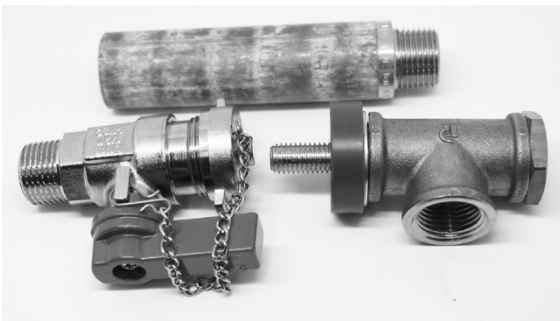

5.3 ASSEMBLY



Set up the storage tank and screw in the levelling feet

Use the levelling feet to adjust the front connections to a minimum of 120 mm and a maximum of 150 mm. Adjust the centre pipe distance from the floor. Align the

storage tank using a spirit level.

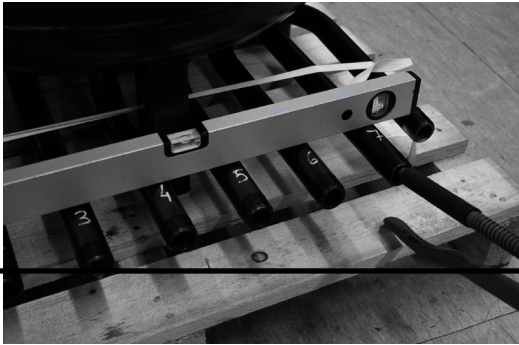

Align the front connections

Use a spirit level to adjust the height. The connections can be aligned using a pipe wrench. Connections Distance control: approx. 85 mm centre-to-centre. Mount 2x RG T-pieces, 1"x1"x1" ÜWM on the two outer storage pipes.

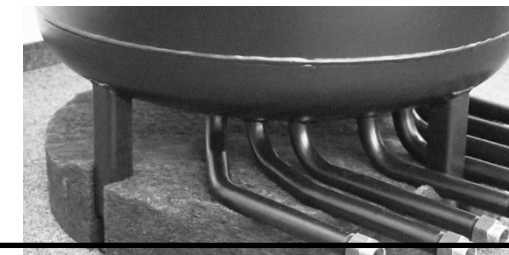

Insert floor fleece, Install insulating half-shells

This requires 2 people. Tension straps may also be required. Please do not tighten too much, as this could cause white breakage. During the cold season, we recommend warming up the storage insulation in a warm room, as this makes it easier to install.



Insert the cover fleece

Ensure that the immersion sleeve is below the round insulation opening so that the sensors can be inserted later.

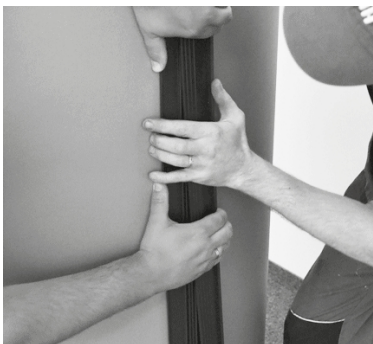

Fit the side closure

Snap into place until the last notch.

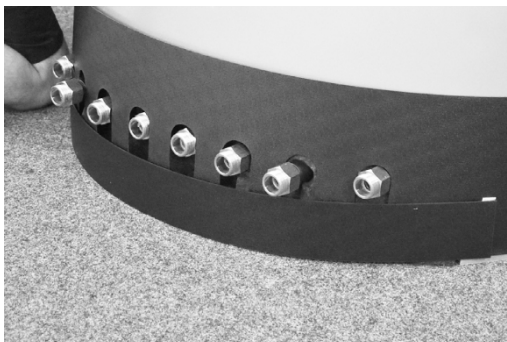

Insert the front fleece at the bottom, fit the decorative trims, fit the cover at the top.

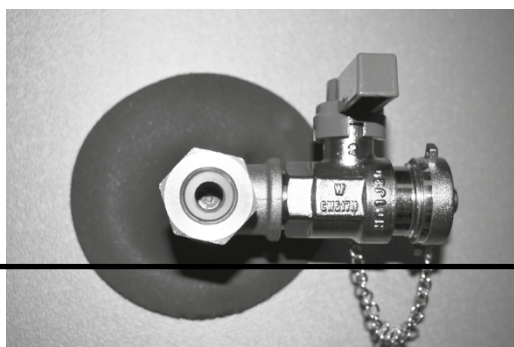

Stick the cover rosette onto the vent connection

Hang the vent pipe from the storage tank and fit the vent set (T-piece).
For 1,000 litres, the connection is via the hydraulic module.
For 500 litres and 750 litres, the connection is located behind the hydraulic module and is also the mounting point for the hydraulic module.

Fit the angle ball valves

The blue and red handles are unscrewed at the factory to make it easier to install the hydraulic module.

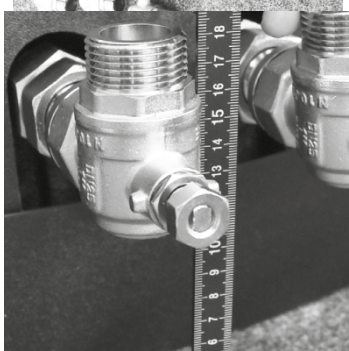
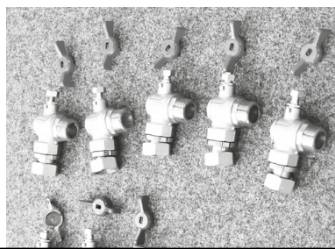

Measuring the ball valve height

The height from the floor to the upper threaded connection point of the ball valve (18 cm in this case) is required.

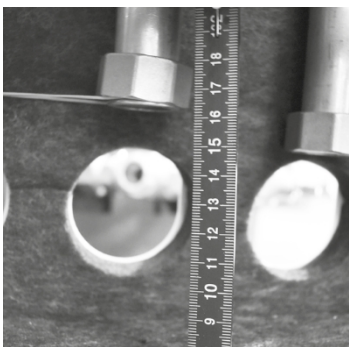

Adjusting the height of the hydraulic module

Adjust the levelling feet of the hydraulic module so that the height of the flat-sealing hydraulic connections with ÜWM (here 16.4 cm) corresponds to the height of the ball valve.

We recommend setting the hydraulic module slightly higher (approx. 18.5 cm), as it is easier to turn the levelling feet inwards than upwards.

Attach the hydraulic module to the storage tank

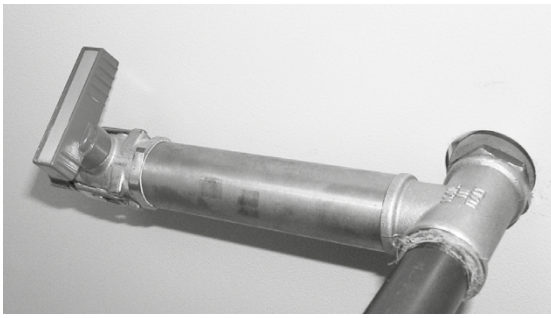

The picture shows the attachment of 500 litre and 750 litre storage tanks. View from the storage tank towards the module.

Tighten the storage tank and module connections



Two open-end spanners (SW36 and SW38) are supplied for this purpose. These two spanners are part of the hydraulic module and remain with the operator at the system.

NOTE: If unsuitable tools, such as pipe wrenches, are used, we will not accept any complaints regarding leaks at the connections.

Fit handles to the corner ball valves blue – red –

blue – red – blue – red – red – blue

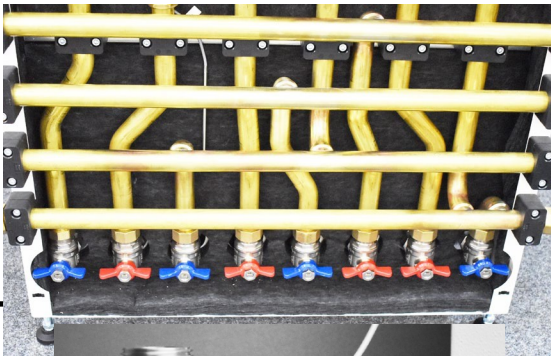

Fit the cold water connection set on the top left side

Press in the rubber grommet, push the pipe through the opening, insert the clamp and tighten the nut, screw the clamp tight, screw the flow turbine onto the stainless steel pipe.
- Flow direction towards the hydraulic module!









Install the hot water connection set on the lower left side.

Press in the rubber grommet, push the pipe through the opening, insert the clamp and tighten the nut, screw the clamp tight.

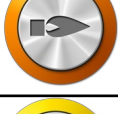

6. HYDRAULICS

6.1 STORAGE TANK CHARGING HYDRAULICS

4	VL	Heating circuit(s) + automatic heat generator		
6	VL	Manual + automatic heat generator		
5	RL	automatic heat generator		
3	RL	automatic heat generator		
8	RL	Solar + manual heat generator		

Shut-off valves at bottom Corner ball valve 1" female thread x 1" male thread

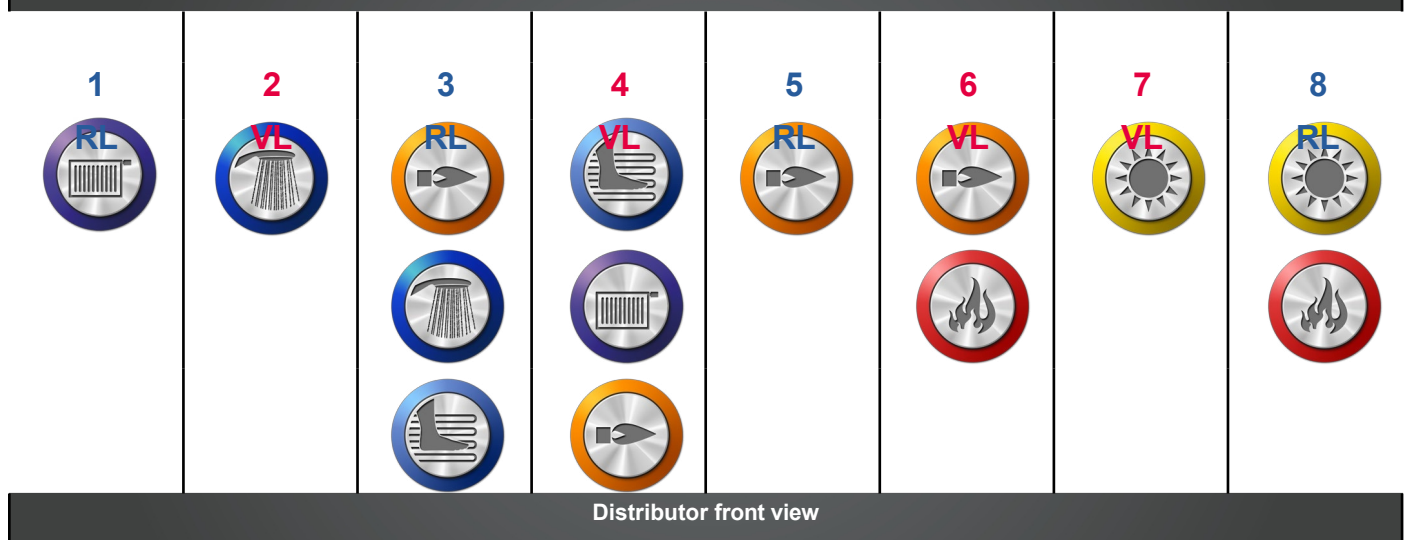

Distributor front view

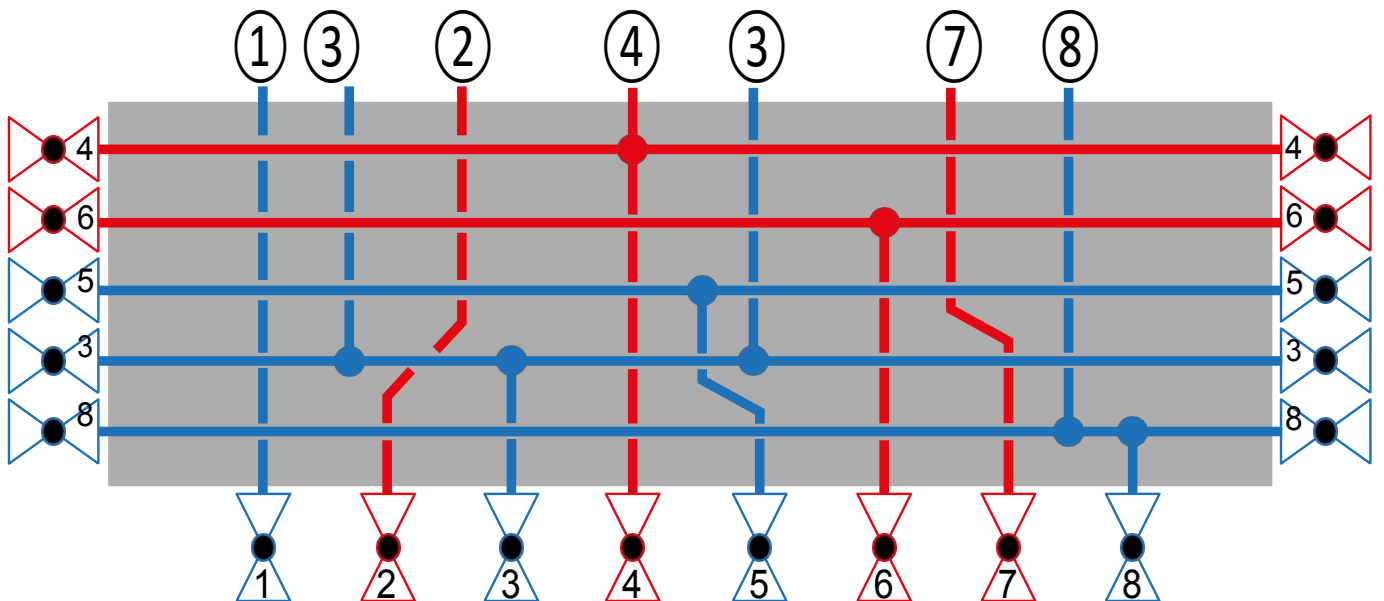

6.2 REQUIREMENTS FOR THE SYSTEM WATER

Parameters	Unit	Concentration	Copper soldered
pH	/	< 6.0	-
		6.0 - 7.5	°
		7.5 - 8.5	+
		8.5 - 10.0	°
		> 10	°
Conductivity	µS/cm	< 10	+
		10 - 500	+
		500 - 1,000	°
		> 1,000	-
Chloride	mg/L	< 10	+
		10 - 50	+
		50 - 80	+
		80 - 100	+
		100 - 1,000	°
		> 1,000	-
Free chlorine	mg/L	< 0.5	+
		0.5 - 1.0	+
		1.0 - 5.0	°
		> 5.0	-
Total hardness	°dH	< 5	+
		5 - 15	+
		15 - 30	°
		> 30	-
Ammonia (NH ₃ , NH ⁺) ₄	mg/L	< 2	+
		2 - 20	°
		> 20	-
Alkalinity (HCO ₃)	mg/L	< 60	+
		60 - 300	+
		> 300	°
Sulphate (SO ₄ ²⁻)	mg/L	< 100	+
		100 - 300	°/-
		> 300	-
HCO ₃ ⁻ / SO ₄ ²⁻	mg/L	> 1.5	+
		< 1.5	°/-
Nitrates (NO ₃)	mg/L	< 100	+
		> 100	°
Hydrogen sulphide (H ₂ S)	mg/L	< 0.05	+
		> 0.05	°/-
Free carbon dioxide (CO ₂)	mg/L	< 5	+
		5 - 20	°
		> 20	-
Manganese	mg/L	< 0.1	+
		> 0.1	°
Iron (Fe)	mg/L	< 0.2	+
		> 0.2	°
Aluminium	mg/L	< 0.2	+
		> 0.2	°

NOTE

- The system water may contain a maximum of 50% glycol.
- Ensure that the device water meets all requirements. If the properties are not optimal (°) for more than two criteria or if one criterion does not meet the minimum requirement (-), no warranty claim can be made.

6.3 HYDRAULIC DIAGRAM

Oskar° 08

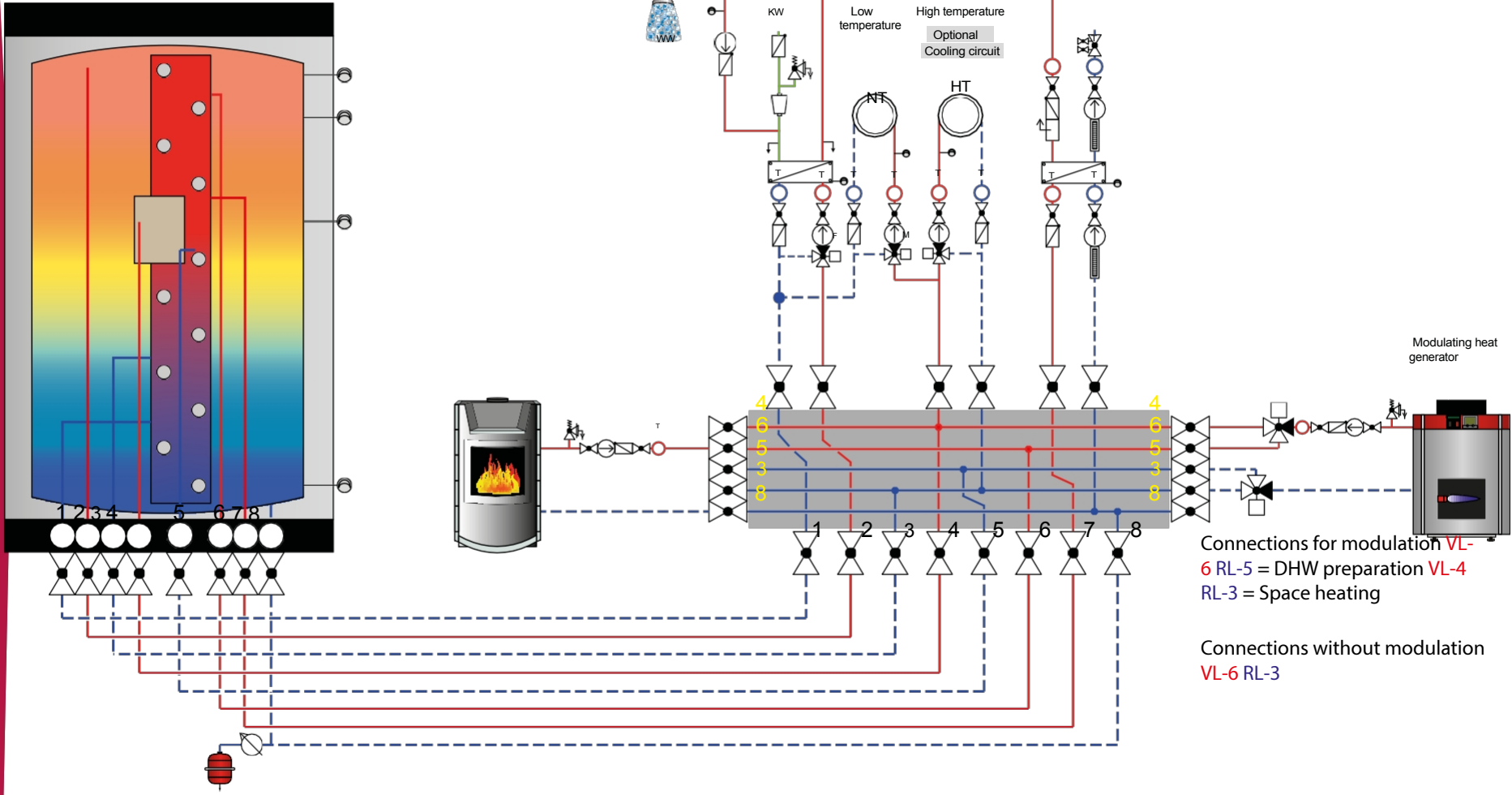

Connections for modulation VL-5
 6 RL-5 = DHW preparation VL-4
 RL-3 = Space heating

Connections without modulation
 VL-6 RL-3

6.4 HYDRAULIC MODULE

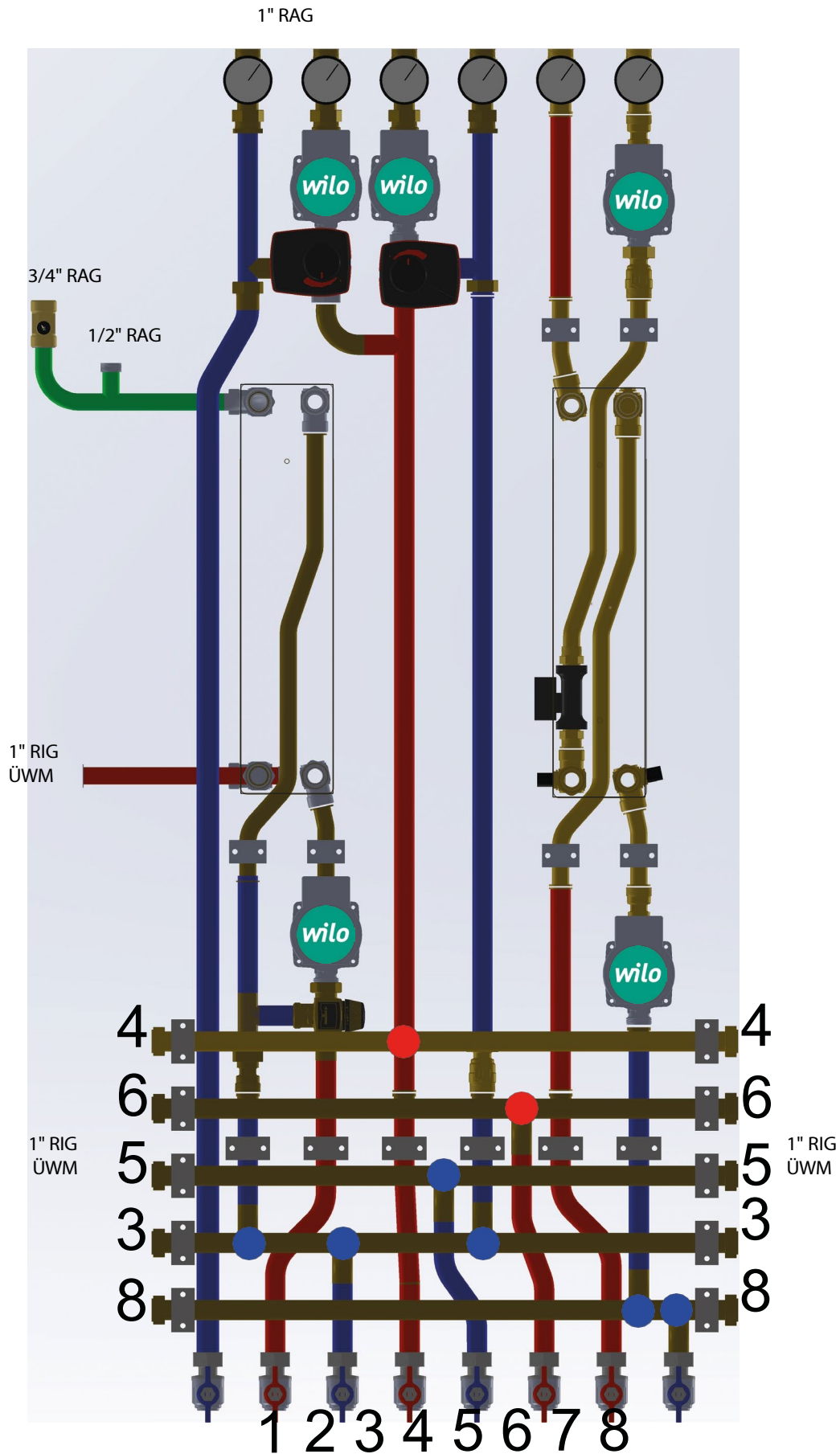

6.5 HYDRAULIC MODULE / ASSEMBLIES MAXIMUM CONFIGURATION

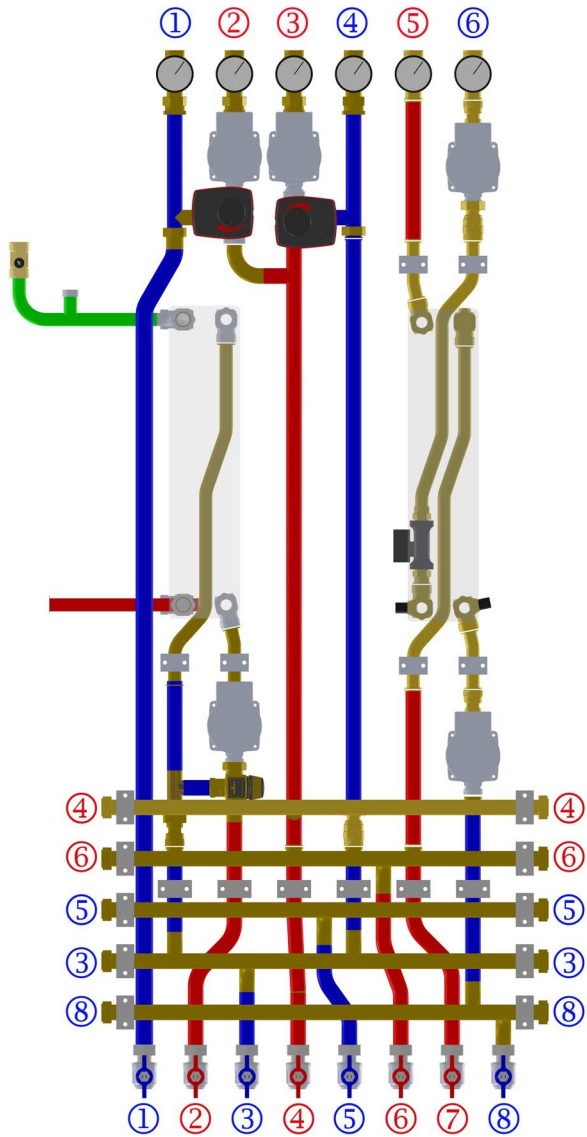

- | | |
|---|--------------------------|
| 1 | Heating circuit 2 return |
| 2 | Heating circuit 2 flow |
| 3 | Heating circuit 1 flow |
| 4 | Heating circuit 1 return |
| 5 | Solar flow |
| 6 | Solar return |

6.5.1 SERVICE CONNECTIONS ON THE BOTTOM OF THE HYDRAULIC MODULE

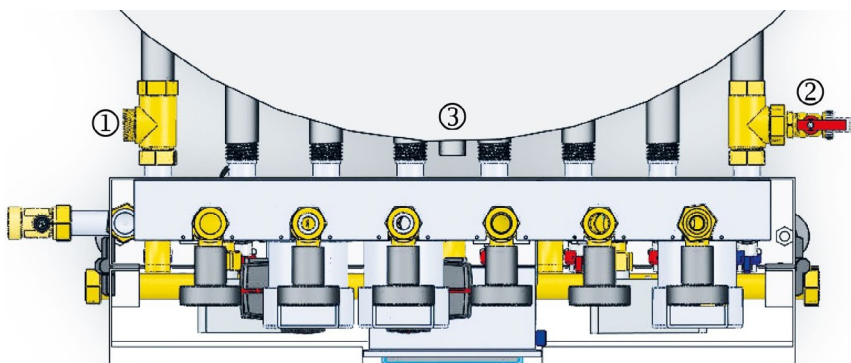

- | | |
|---|------------------------------------|
| 1 | Connection for expansion vessel |
| 2 | Storage tank drainage with KFE tap |
| 3 | Storage tank venting |

6.6 DRINKING WATER STATION TWST

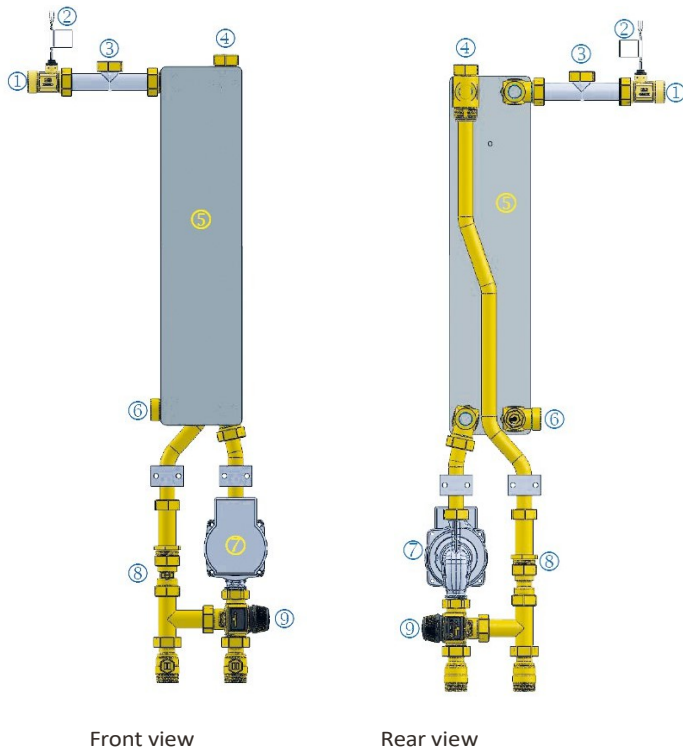

- | | |
|---|--|
| 1 | Cold water inlet connection |
| 2 | Turbine flow sensor (S15) |
| 3 | Circulation connection |
| 4 | Return flow of optional heating circuit 2 |
| 5 | Plate heat exchanger |
| 6 | Hot water outlet connection |
| 7 | Circulation pump (A16 PWM) 2-pin cable |
| 8 | Gravity brake with manual adjustment |
| 9 | Heating water mixing valve (optional) |

Performance data TWK

					Unit
Heat output	80	98	70	78	kW
Heating water inlet	70	70	60	60	°C
Heating water outlet	24	14	21	15	°C
Cold water inlet	10	10	10	10	°C
Hot water outlet	60	40	50	40	°C
Hot water volume	23	47	25	37	l/min

6.7 CIRCULATION PUMP



Delivery head / volume:	8.4 metres / 1.2 m ³ /h
Max. flow rate:	4.0 m ³ /h
Max. medium temperature:	95 °C
Voltage:	1 ~ 230V +10 %/-15 %, 50/60 Hz
System temperature:	-10 °C to +95 °C (non-freezing)

6.7.1 CIRCULATION STATION COMPONENTS

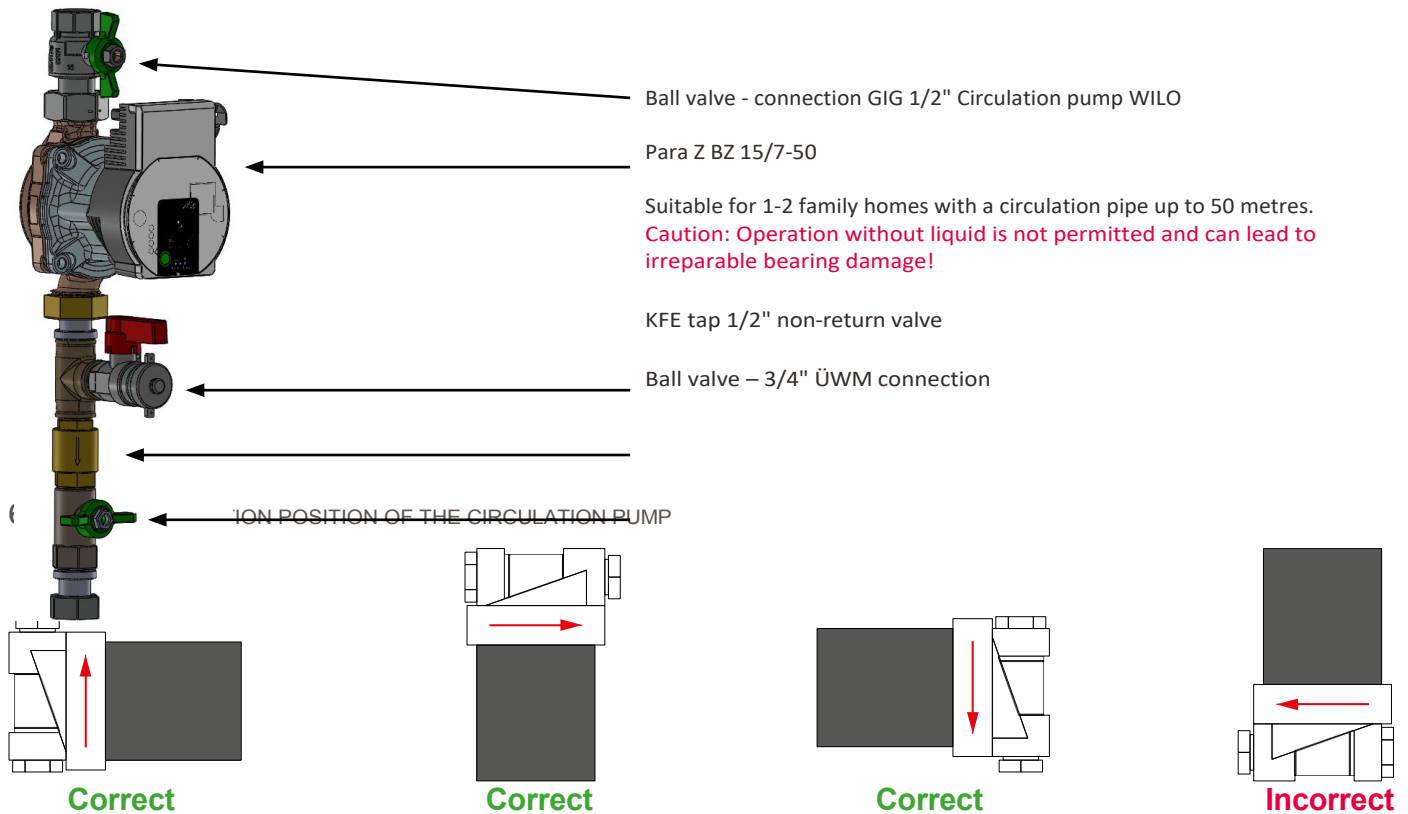

6.7.3 CIRCULATION REQUEST

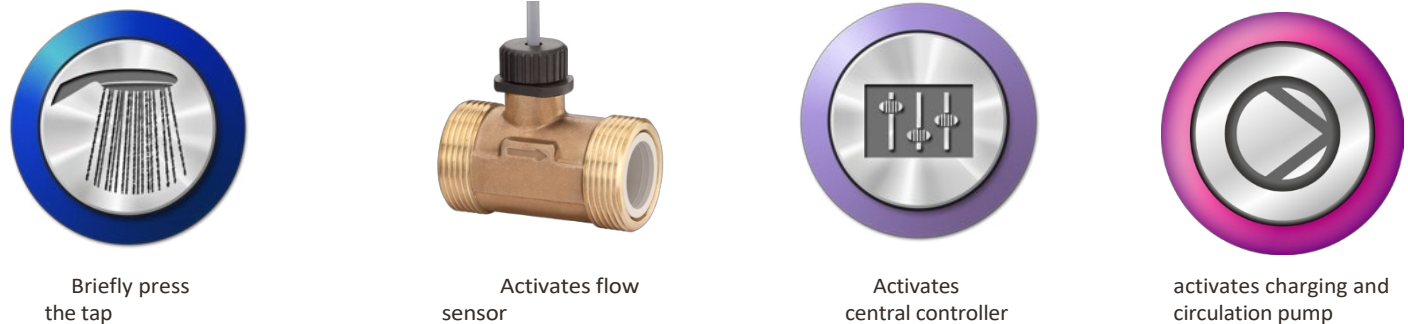

6.7.4 HEATING CIRCUIT



- 1 Return connection with thermometer HK2

- 2 Flow connection with thermometer HK2

- 3 Flow connection with thermometer HK1

- 4 Return connection with thermometer HK1

6.8 HEAT METER RETROFIT

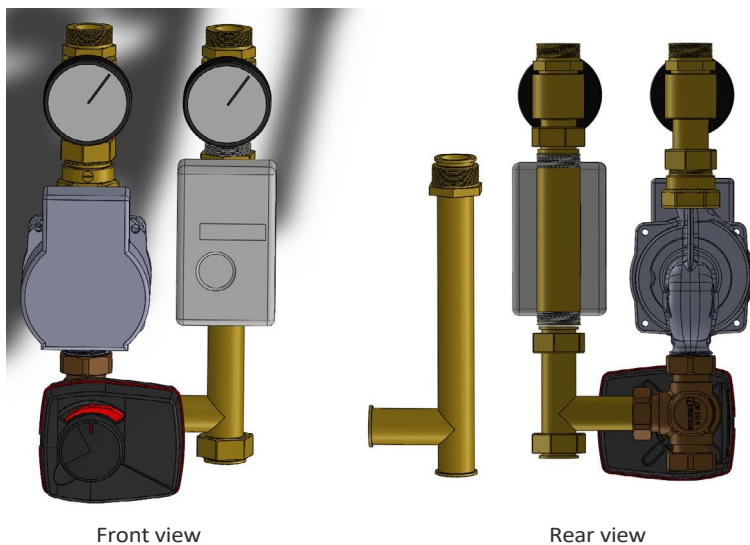

- 1 Remove the return pipe

- 2 Remove display thermometer

- 3 Fit the T-piece and WMZ

- 4 Fit the display thermometer

6.9 SOLAR STATION 6-16

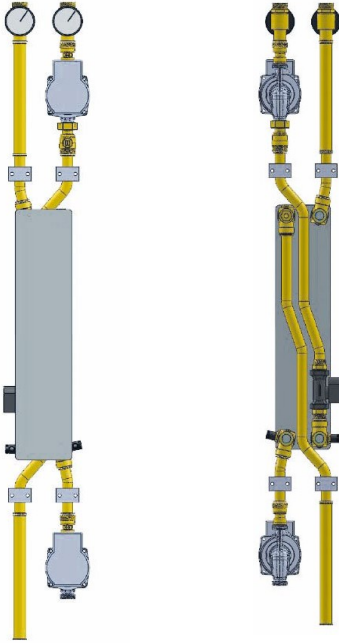

Solar flow connection Cutting ring Solar
secondary circuit Cutting ring Solar
primary pump (PWVW) Heat exchanger
Flow rate adjustment valve Solar
secondary pump (PVM)

Connect the solar circuit pipes to the upper connections using compression fittings. If using **soft, thin-walled pipes, support sleeves** must be used to provide additional stability. The pipe ends must be cut at right angles and free of burrs. Push the pipe in as far as it will go and tighten the compression ring fitting using a suitable tool (open-end spanner or similar). When tightening, use a suitable tool (not a pump/pipe wrench) to hold the pipe in place.



The solar system must already be filled with heat transfer fluid in the primary circuit and with water in the secondary circuit, vented and at the required operating pressure.

The secondary flow rates are set automatically by the controller.

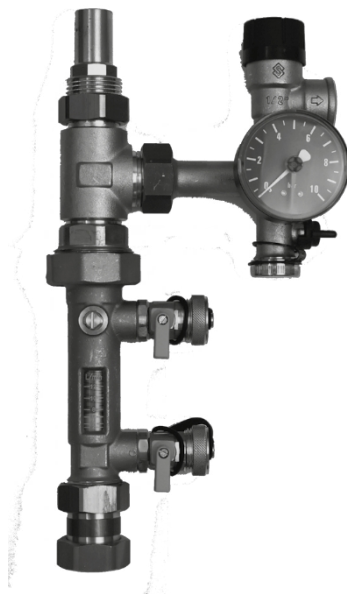

Filling, flushing and safety device Solar (scope of delivery of the optional solar system) consists of:

- 2x universal adapters 22 mm, optionally for pressing, soldering or cutting ring screw connections.
- Flushing device with flow rate adjustment valve.
- 10 bar pressure gauge.
- 6 bar safety valve.
- Filling and draining ball valve.



6.9.1 ACCESSORIES

Solar station primary pump settings (collector circuit):

- In the "Outputs" menu on the controller, set the 0-10 V output for PWM control to "Manual". This opens a button below where you can set any control (0-100%).
(0%=OFF, <10%=min. throughput, 100%=max. throughput)
- Increase the control gradually starting at 10% until the mass flow at the throttle device exceeds 2 l/min.
This is considered the critical lower limit and is therefore the minimum control setting.
Gradually increase the control until the volume flow to be achieved according to the table can be read at the throttle device.
This value is considered the maximum upper limit and is therefore the maximum control setting.
- Both values must now be parameterised on the controller.
=> In the function overview, enter the service menu, enter the specialist code, confirm and select the primary pump under the solar pumps tile.
Now enter the minimum and maximum PWM control values determined earlier as a percentage and confirm.

Low-flow system (m²)	10	12.5	15	17.5	
V primary (l/min)	4.4	5.2	6.3	7.3	
V secondary (l/min)	3.8	4.4	5.3	6.2	
Max. power range (kW)	~	8.0	10.0	12.0	14.0



Pre-control valve ra/28.90.5701 (optional) consisting of:

- 1x VTA378 mixing valve, 30-70°, DN20
- Recommended for use with solar thermal energy and high-temperature heat generators as protection against calcification

Stages	1	2	3	4	5	6
Measured	36	42	49	53	59	68
Manufacturer's specifications	35	40	50	55	60	70

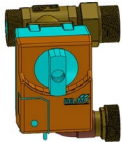

Switch module for modular WE ra/28.90.0001 (optional) consisting of:

- 2x switch ball valve, 3-way, DN15, 1" AG
- as well as various



switching module for cooling ra/28.90.0005

- 1x switchover ball valve, 3-way, DN15, 1" AG
- 1x compact actuator TRY 230V, 35s
- 1x ball valve DN25 flat sealing (RG) 905003
- and other screw connections, elbows and special pipe set

7. CENTRAL CONTROL UNIT

7.1 SAFETY REGULATIONS



NOTE: The following pages contain the service instructions and are intended exclusively for **authorised** specialists.

All installation and wiring work on the controller must only be carried out when the power is disconnected.

The device may only be opened, connected and commissioned by qualified personnel.

All local safety regulations must be observed.

The device is state-of-the-art and complies with all necessary safety regulations.

It may only be used in accordance with the technical data and the safety regulations and instructions listed below.

When using the device, the legal and safety regulations required for the specific application must also be observed.

Improper use will result in the exclusion of any liability claims.

- Installation may only be carried out in dry indoor areas.
- The controller must be able to be disconnected from the mains using an all-pole disconnecting device in accordance with local regulations. (Plug/socket or 2-pole disconnect switch)
- Before starting any installation or wiring work on equipment, the controller must be completely disconnected from the mains voltage and secured against being switched on again.
- Solar systems can reach very high temperatures. There is therefore a risk of burns. Take care when installing temperature sensors.
- For safety reasons, the outputs may only remain in manual mode for testing purposes. In this operating mode, maximum temperatures and sensor functions are not monitored.
- Safe operation is no longer possible if the controller or connected equipment shows visible damage, no longer functions or has been stored for a long period of time under unfavourable conditions. If this is the case, the controller or equipment must be taken out of service and secured against unintentional operation.



The device does not require maintenance if handled and used properly.

Only use a cloth moistened with mild alcohol (e.g. methylated spirits) for cleaning. Strong cleaning agents and solvents such as chlorethene or trichloroethylene are not permitted! As none of the components relevant to accuracy are subjected to stress when handled properly, long-term drift is extremely low. The device therefore has no adjustment option. This means that calibration is not necessary. The design features of the device must not be changed during any repairs. Spare parts must correspond to the original spare parts and be used in accordance with the factory settings.

7.2 SENSOR IMMERSION SLEEVE

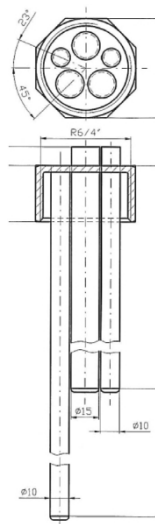

- 3x Ø15/1mm and 2x Ø10/1mm
- Sensors are factory configured and labelled
- Insert the sensor into the immersion sleeve up to the cable tie position
- If necessary, extend the sensors in accordance with VDW regulations to ensure a secure connection.

Immersion depth of the sensors in the immersion sleeve:

Type:	500 l	750 l	1,000 l	Unit
Hot water minimum (S2):	200	200	200	mm
Hot water maximum (S3):	540	450	450	mm
Heating (S4):	900	810	810	mm
Storage tank below (S5):	1,500	1,500	1,880	mm

Ultra-fast sensor installation



Caution: there is a risk of flooding!

The lock nut for the O-ring seal of the sensor element must be tightened professionally so that the sensor cannot be pushed out by the internal water pressure!

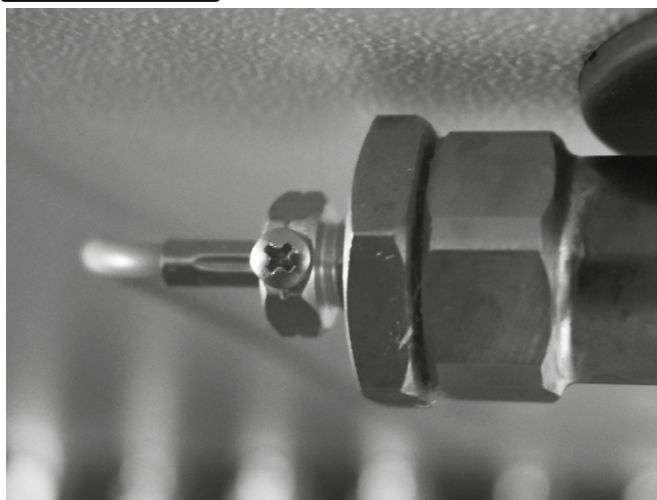

7.3 TURBINE FLOW SENSOR

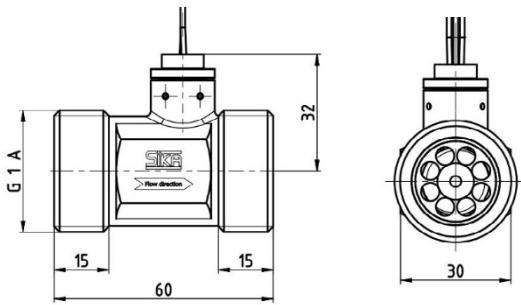

Low wear and extremely long service life thanks to high-quality bearings.

Virtually no series variation due to fixed pulse rate.

Wide measuring range (up to 1:60), insensitive to pressure surges, proven in numerous large-scale applications.

High measuring accuracy, largely independent of installation position due to integrated flow alignment.

Colour code for stranded cables
! Connect all wires!

Green	S15 Signalinput
Brown	GND Ground

Electrical connection 80 mm single wire with 0.5 m PVC cable

Technical data:

Material/pipe section:	Brass
Measuring range:	1 to 60 l/min
Measuring accuracy:	± 1% of the measuring range end value ± 1% of the measured value
Repeatability:	± 1%
Signal output:	from 0.8 l/min
Media temperature:	0 to 90 °C
Ambient temperature:	0 to 70 °C
Nominal pressure:	PN 16
Nominal diameter:	DN 20
Process connection:	G 1 external thread
Measuring sensor:	Hall effect sensor
Output signal:	Square wave frequency signal, NPN open collector
Duty cycle:	50:50
Pulse rate / K factor	119 pulses/l
Supply voltage:	4.5 to 24 VDC
Pressure loss:	0.33 bar (at Q = 60 l/min)

Function:

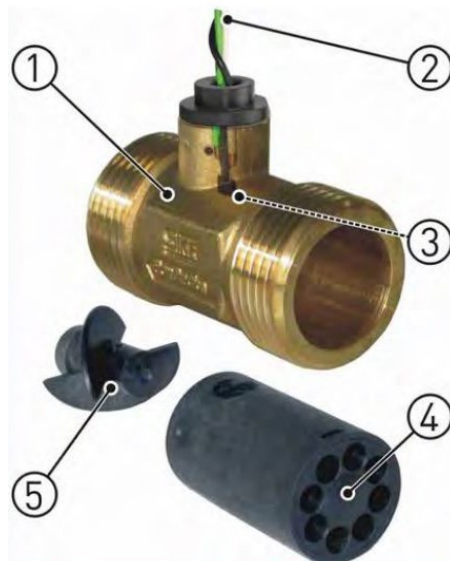

The fluid flowing into the VTY causes rotor 5 to rotate. The forces generated during rotation are largely absorbed by the symmetrical shape of the rotor, reducing wear to a minimum.

The rotor 5 at the VTY is equipped with a magnet.

A Hall effect sensor 3 detects the rotation of the rotor and converts this into a frequency signal (square wave signal) proportional to the flow rate.

The extremely hard bearing materials, sapphire and carbide, also guarantee an exceptionally long service life.

731 INSTALLING THE VTY20

In principle, the VTY can be installed at any point in the pipeline. Straight pipe sections are preferable.

It can be installed in both horizontal and vertical pipes.

The flow sensor is only suitable for use in completely filled pipes. You must avoid free outflow at all costs.

The arrow on the flow sensor indicates the only possible flow direction.



CAUTION! Material damage!

Observe the maximum torque. When tightening the union nut on the turbine body of the device, hold it in place! Without holding it in place, the VTY may be damaged.

Tighten the two union nuts. Hold the turbine body of the device in place with an open-end wrench (SW19/SW30).

VTY10MA • G½

20 Nm

SW19

Maximum torque / spanner size

VTY10K15 • G¾

8 N·m

SW19

VTY20MA • G1

20Nm

SW30

Check that

- the VTY has been installed correctly and all screw connections are tight.
- the electrical connections have been made correctly.
- The measuring system has been vented by flushing.
- The VTY has no switch and cannot be switched on or off independently.
- It is switched on and off via the connected supply voltage.
- Switch on the supply voltage.
- The VTY is ready for operation and switches to measurement mode.

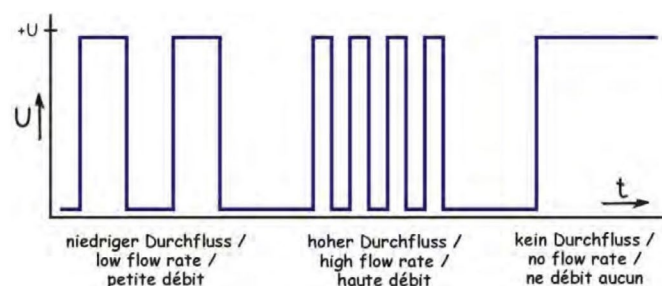

In measurement mode, the VTY delivers an NPN square wave signal proportional to the flow rate.

The frequency of the output signal changes according to the flow rate.

7.4 SENSOR



Cable sensor

- PT1000B (-40 to +180°C)
- 5 m silicone cable
- Sensor Ø 5.5 mm



Collector sensor

- PT1000B (-40 to +180°C)
- 2.5 m silicone cable
- Sensor Ø 5.5 mm
- with overvoltage protection

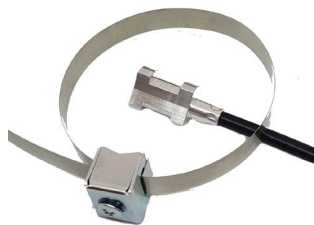

Pipe contact sensor

- PT1000B (-40 to +180°C)
- 5.0 m silicone cable
- Mounting clamp
- Thermal paste



"Ultra-fast" cable sensor

- PT1000B (-40 to +180°C)
- 5 m PVC cable
- Brass screw connection ½" AG



Outdoor sensor

- PT1000B (-40 to +180°C)
- with overvoltage protection



Turbine flow sensor VTY 20

741 OPTIONAL ACCESSORIES



Room setpoint transmitter RSG-Plus

- DI bus device
- Potentiometer ($\pm 5^{\circ}\text{C}$)
- Operating mode selector switch



Room remote control

- With its 4.3" touch display, the CAN-MTx2 is an operating and display unit for the freely programmable universal controllers UVR16x2, RSM610 and all x2-compatible devices. It has the operating concept of the UVR16x2 controller and has a sensor unit for room temperature, humidity and air pressure.



CAN IO45 expansion module

- with 4 inputs
- with 3 relay outputs
- with 2 multifunction outputs (0-10 volts or PWM)
- CAN bus and DL bus for external sensors
- with sensors as required

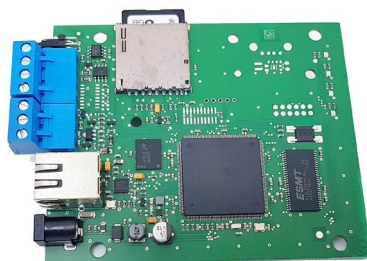

C.M.I circuit board module

- The C.M.I (Control and Monitoring Interface) is an interface for convenient system monitoring, remote control, data logging and visualisation of all ra controllers with DL or CAN bus.



Electronic volume flow sensor EVS

- DN 10: Flow rates between 2.0 and 32 litres per minute = Standard EVS for solar thermal systems up to 60 m² (flat-plate collector)
- Recording of medium temperatures from -40 to +125°C (PT1000).
- Output of measured values via DL bus.

7.5 TECHNICAL

All inputs:	Temperature sensor types PT1000 (standard sensor for ratiotherm), KTY 10 (2 k Ω /25°C), KTY 10 (1 k Ω /25°C), PT100, PT500, Ni1000TK5000 and room sensors RAS or RASPT, radiation sensor GBS01 thermocouple THEL, humidity sensor RFS, rain sensor RES01, pulses max. 10 Hz, voltage up to 3.3V DC, resistance (1-100k Ω), and as digital input
Input 7:	Additional voltage (0-10 volts DC)
Input 8:	Additional current loop (4-20 mA DC), voltage (0-10 volts DC) Additional pulse inputs max. 20 Hz, e.g. for volume flow sensor VIG or SO signal
Inputs 15, 16:	To avoid fluctuations in measured values and ensure interference-free signal transmission, make sure that the sensor cable is not exposed to any external negative influences from 230V cables. The sensor cables must not be routed together with the mains voltage in a single cable. When using unshielded cables, sensor cables and 230V cables must be laid in separate or partitioned cable ducts and with a minimum distance of 5 cm between them. Sensor cables for PT100 or PT500 sensors must be shielded. All sensor cables with a cross-section of 0.5 mm ² can be extended up to 50 m. With this cable length and a PT1000 temperature sensor, the measurement error is approx. +1 K. For longer cables or a lower measurement error, a correspondingly larger cross-section is required. Relay outputs, some normally closed and normally open (max. switching capacity 230 volts / 3 amps)
Outputs 1, 2, 3, 4, 6, 7, 8, 9, 10, 1:	
Output 5 (12, 13 optional):	Relay changeover contact – potential-free
Outputs 12, 13, 14, 15, 16:	Analogue outputs 0-10 volts (max. 20 mA) or PWM (10V/1kHz) or expansion option as switching outputs via additional relays (max. 3A)
Max. bus load (DL bus):	100%
CAN bus:	Standard data rate 50 kbit/s, adjustable from 5 to 500 kbit/s.
Differential temperature:	with separate switch-on and switch-off difference
Threshold values:	with separate switch-on and switch-off difference or with fixed hysteresis
Temperature measuring range:	-49.9°C to +249.9°C with a resolution of 0.1K
Temperature accuracy:	typ. 0.4K, max. \pm 1K in the range from 0-100°C for PT1000 sensors
Voltage accuracy:	typ. 1%, max. 5% of the maximum measuring range of the input
Connection:	230 volts, 50-60Hz, (outputs A1 to A11 and devices jointly fused with 6.3A fast-acting fuse)
Supply cable:	3x1 mm ² H05VV-F according to EN 60730-1
Power consumption:	3.5 to 4 watts per active switching output
Power reserve:	In the event of a power failure, the controller has a power reserve of approx. 3 days for the date and time.
Permissible ambient temperature: +5 to +45°C	
Protection class:	IP 40 (controller and housing) = protected against solid foreign objects with a diameter of 1.0 mm or more; protected against access with a wire; no protection against water.

751 DL INPUTS

DL input:	Designation:
1/11	Room setpoint sensor heating circuit 1
1/12	Room setpoint sensor for heating circuit 2
3/2	Temperature measurement in solar thermal return (primary circuit)
3	Flow detection in solar thermal return flow (primary circuit)

The DL bus consists of 2 wires: DL and GND (sensor ground).

The power supply for the DL bus sensors is provided by the DL bus itself. Some DL bus devices can/must be powered by a 12V source, e.g. that of the CAN bus (this is explicitly stated in the operating instructions for that sensor).

The cables can be laid in a star configuration or in series (from one device to the next). Any cable with a cross-section of 0.75 mm² and a maximum length of 30 m can be used as a data cable. For lengths over 30 m, the use of shielded cables is recommended, which increases the permissible length of the cable to 100 m. Long cable ducts for power and data cables laid close together cause interference from the power supply to be introduced into the data cables. A minimum distance of 20 cm between the cable ducts or the use of shielded cables is therefore recommended.

When recording two control systems with a data logger, separate shielded cables must be used. The data cable must never be routed in the same cable as a CAN bus cable!

Each DL sensor must have its own DL bus address.

In most cases, the address is adjusted via DIP switches on the device circuit board.

Most DL sensors can record different measured values (e.g. volume flow and temperatures).



Setting is pre-coded at the factory.

Changes according to the original operating instructions supplied.



The device has DL address 1 when delivered.

The standard programming is 3.
This means switches 1 + 2 are set to "ON".

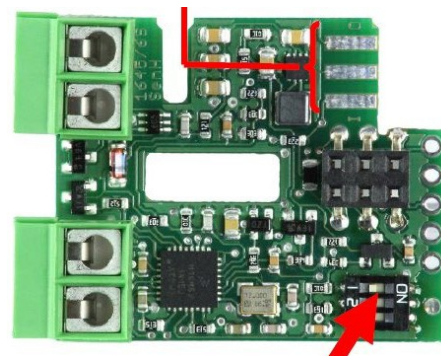

7.6 INSTALLATION/REMOVAL OF THE CONTROLLER

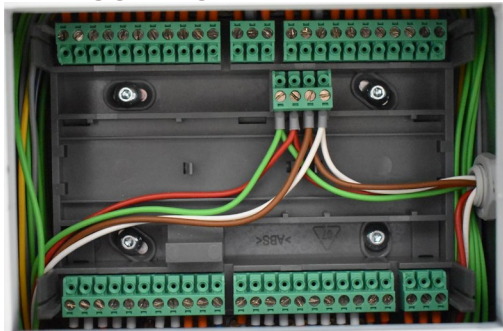

After you have pushed the controller into the mounting shaft of the housing, connect it to the motherboard by pressing firmly on the edge of the controller.

Please do not put any strain on the display when doing so.



To remove the controller, carefully press in the two lateral locking claws of the controller with two wide flat-head screwdrivers and carefully lever out the controller.

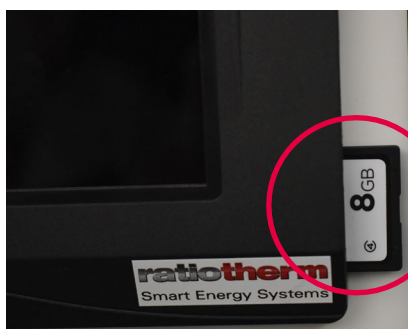

The **SD card** is located in the lower right-hand corner of the controller.

To make it easier to remove or insert the card, the controller should be removed from the housing.



Handhabung

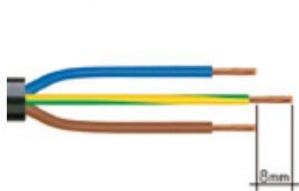

1. Abmantelllänge = x mm * ①
2. Abisolierlänge = 9 mm
3. Voreilung PE-Leiter = 8 mm

* Abmantelllänge abhängig von der Polzahl

- ① Abmantellänge 2-polig = 32 mm, 3-polig = 40 mm, 4- und 5-polig = 45 mm

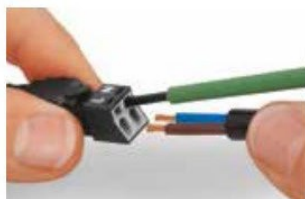

Zum Anschluss feindrähtiger Leiter mittels Betätigungswerkzeug, Klingenbreite 2,5 mm, die Klemmstelle betätigen, den Leiter einführen und das Werkzeug wieder entfernen.



Den verdrahteten Steckverbinder auf das Unterteil einrasten.



Die Steckverbindung durch Aufrasten des Obergehäuses vervollständigen.

7.6.1 PLUG-IN STRIP

BASIS				
12 V Voltage Emergency mode PWM	External sensor S1	Upper storage tank sensor WW minimum S2	Upper storage tank sensor DHW maximum S3	230 volt mains supply
CAN bus L+H	24 volt +/- voltage	Storage sensor centre Room heating S4	Storage sensor solar + WE 2 S5	Mains 230 volts output

HEATING CIRCUIT				
		Flow sensor heating circuit 1 S11	Charging pump heating circuit 1 A3	Mixer heating circuit 1 A1 = OPEN / A2 = CLOSED
DL		Flow sensor heating circuit 2 S12	Charging pump heating circuit 2 A10	Mixer heating circuit A8 = OPEN / A9 = CLOSED

DRINKING WATER HEATING				
		Charging pump TWK Speed control A16 PWM	TWK charging pump standby 230V	TWK / Turbine DHW demand S15 + 24 volts
DHW circulation return sensor S14		Ultra-fast sensor hot water S13	Circulation pump hot water A7	Changeover valve, top/middle of storage tank A4

SOLAR THERMAL				
	Collector sensor S7	Solar charging pump 1 Speed control A14 PWM	Solar charging pump 1 standby 230V	Cooling via valve A11
DL	Heat exchanger sensor S8	Charging pump Solar 2 Speed control A15 PWM	Charging pump solar 2 standby 230V	Cooling via pump A11

HEAT GENERATOR				
	Pump manual WE Speed control A12 PWM	Requirement 0-10 volts A13 PWM	Charging pump WE 1 230V A6	Request WE 1 potential- free A5
Input unused S6	Input unused S16	Flow sensor manual WE S10	Flow sensor WE 2 S9	CAN bus L+H

7.7 INPUT ASSIGNMENT

Connector strip:	Sensor:		Designation:
Base	S1	GND	External sensor
Base	S2	GND	Storage sensor top 1 (hot water minimum)
Base	S3	GND	Storage tank sensor top 2 (hot water maximum)
Base	S4	GND	Storage tank sensor centre (space heating)
Base	S5	GND	Bottom storage tank sensor (reference sensor for solar thermal energy, manual WE1)
Heat generator	S6	GND	Reserve input (not used in standard system)
Solar	S7	GND	Collector sensor with overvoltage protection
Solar	S8	GND	Solar heat exchanger (secondary side flow)
Heat generator	S9	GND	1st automatic heat generator – flow temperature
Heat generator	S10	GND	Manual heat generator (wood-burning stove) – flow temperature
Heating circuit	S11	GND	Heating circuit 1 - Flow temperature
Heating circuit	S12	GND	Heating circuit 2 - Flow temperature
Drinking water	S13	GND	Hot water - outlet temperature (ultra-fast sensor)
Drinking water	S14	GND	Hot water circulation - return temperature
Drinking water	S15	GND	Flow turbine VTY20 (hot water request) +24 volts
Heat generator	S16	GND	Reserve input (not used in standard configuration)

CABLE DIAGRAM:

Up to 100 metres cable length:

Power supply - 3x1.5mm² Sensors -

2x0.75mm² Outputs - 3x0.75mm²

Mixer - 4x0.75mm²

78 OUTPUT ASSIGNMENT

Power strip:	230 V outputs:		Designation:
Heating circuit	A1	N/PE	Heating circuit 1 – mixer ON
Heating circuit	A2	N/PE	Heating circuit 1 - Mixer CLOSED
Heating circuit	A3	N/PE	Heating circuit 1 charging pump
Drinking water	A4 S	N/PE	Changeover valve – storage tank charging top (hot water preparation)
	A4 Ö		Changeover valve – storage tank charging centre (space heating)
Heat generator	A5	W+S	Request – automatic heat generator 1 (potential-free)
Heat generator	A6	N/PE	Charging pump – heat generator 1 (automatic heat generator)
Drinking water	A7	N/PE	Circulation pump for hot water
Heating circuit	A8	N/PE	Heating circuit 2 - Mixer ON
Heating circuit	A9	N/PE	Heating circuit 2 - Mixer CLOSED
Heating circuit	A10	N/PE	Heating circuit 2 – charging pump
Solar	A11 S/Ö	N/PE	Cooling valve (OPEN/CLOSED)
	A11 S		Cooling pump
PWM outputs:			
Heat generator	A12 PWM	GND	Charging pump – manual heat generator (speed control)
Heat generator	A13 PWM	GND	Request – automatic heat generator 1 (0–10 volts)
Solar	A14 PWM	GND	Solar pump 1 (primary/collector circuit)
Solar	A15 PWM	GND	Solar pump 2 (secondary/storage circuit)
Drinking water	A16 PWM	GND	Compact drinking water station PWM signal

79 INPUT AND OUTPUT ASSIGNMENT RSM 610

Connector strip:	230 V outputs:		Designation:
Output 1	A1	N/PE	Charging pump 2 – automatic heat generator (230 volts)
Output 3+4	A3	N/PE	Mixer return flow boost (OPEN)
	A4	N/PE	Mixer return lift (CLOSED)
Output 6	A6	W	Requirement 2 – automatic heat generator (potential-free)
	A6	S	Requirement 2 – automatic heat generator (potential-free)
Output 10	A10	GND	Requirement 2 – automatic heat generator (modulation 0–10 volts)
Input 1	S1	GND	Flow temperature – automatic heat generator 2
Input 2	S2	GND	Fault - automatic heat generator 2
Input 3	S3	GND	Fault - automatic heat generator 1
Input 4	S4	GND	Return temperature – automatic heat generator 2



ATTENTION! When using the additional module, always ensure **PHASE EQUALITY**.

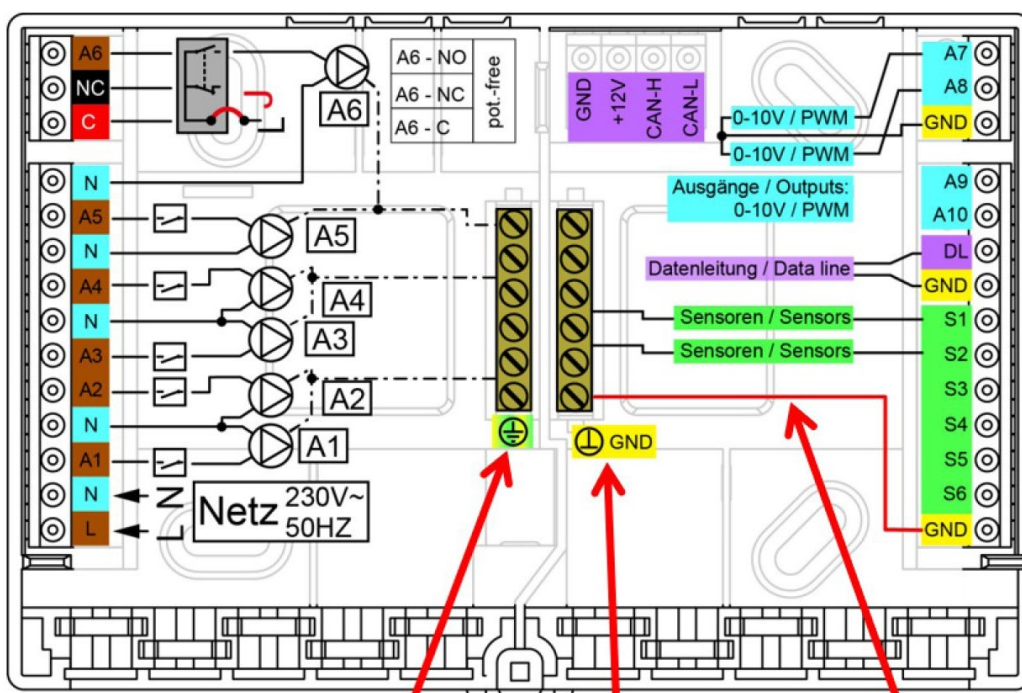

7.10 WIRING OF COMPONENTS

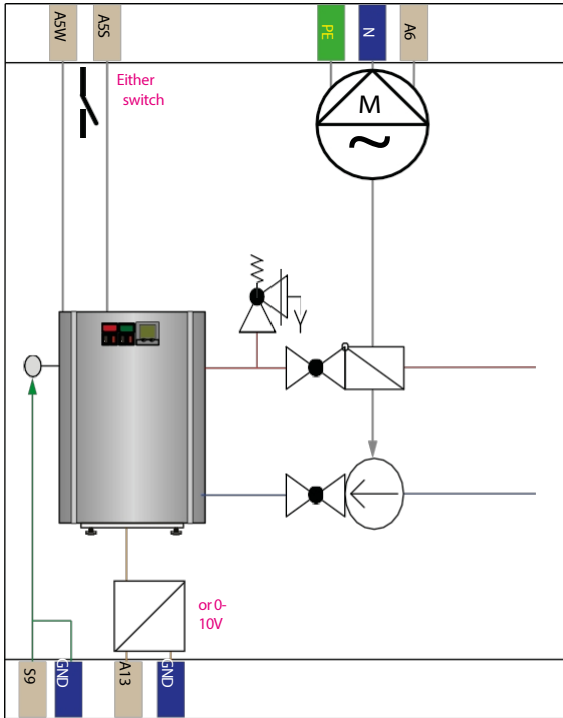

**Heat generator 1
Automatic**

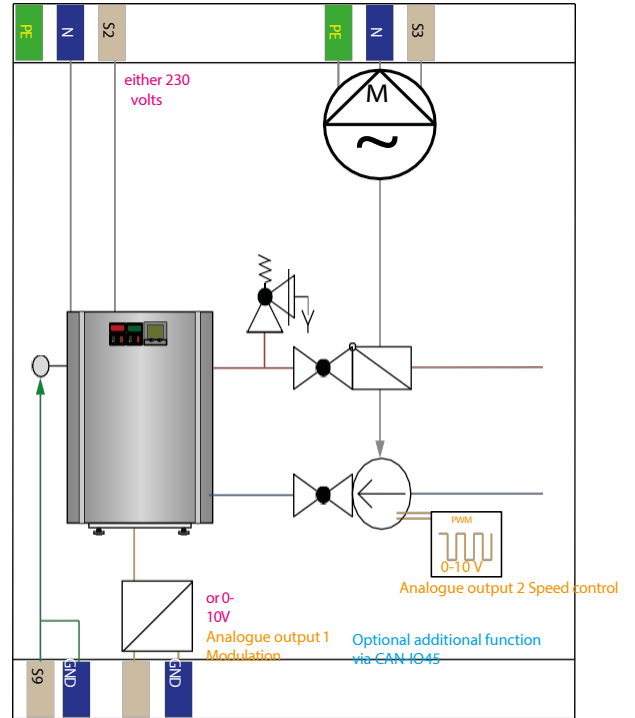

**Heat generator 2
Automatic**

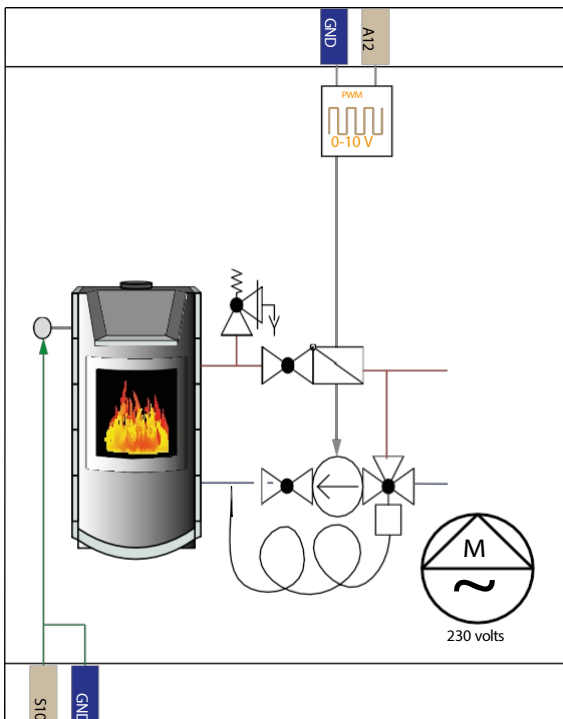

**Heat generator
Manual**

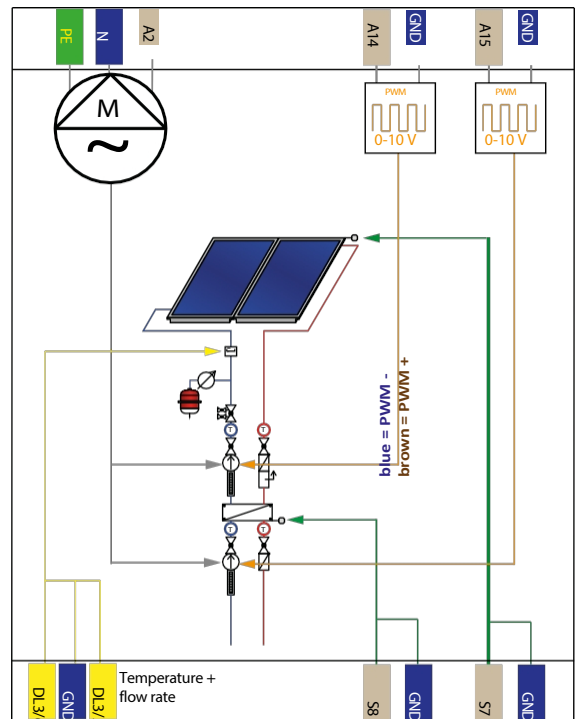

Solar thermal

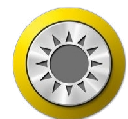

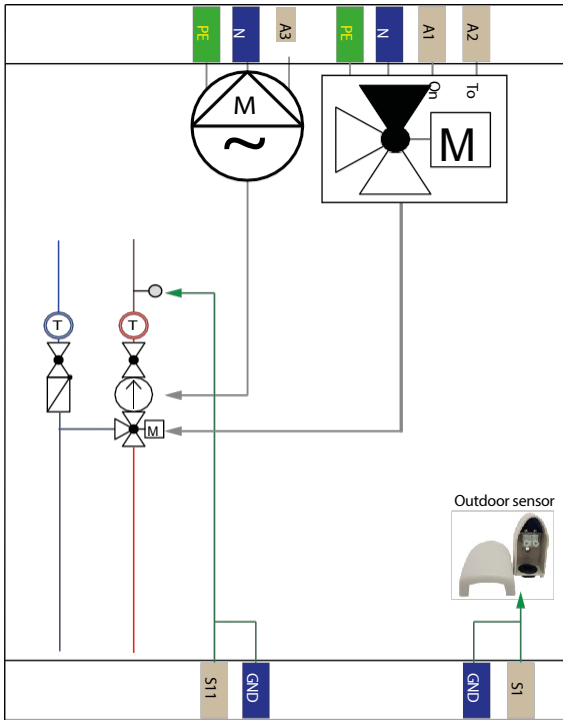

Heating circuit 1

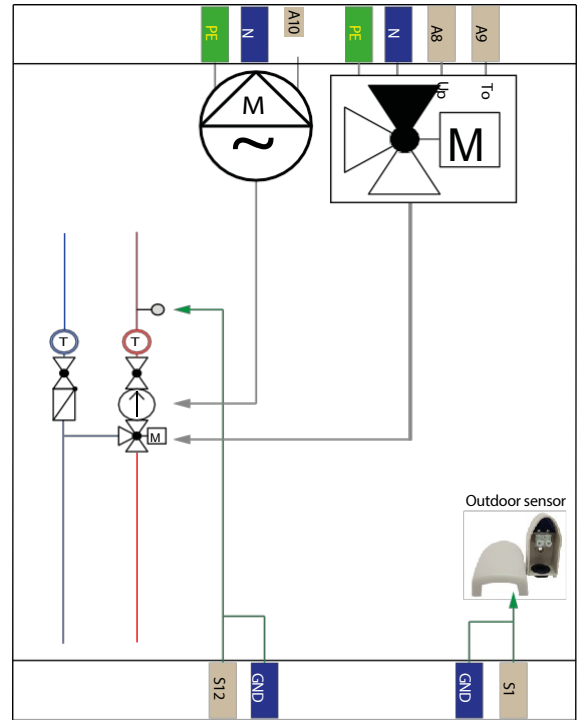

Heating circuit 2

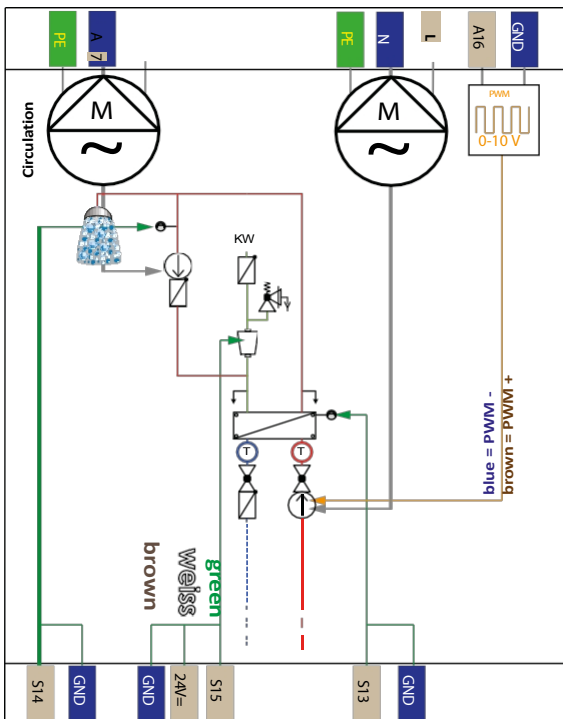

Drinking water heating



8. CONTROLLER OPERATION

8.1 CONFIGURATION OF THE CONTROLLER



When starting the controller for the first time, it must be configured according to the available components.



To start the configuration, first enter the specialist code and confirm with ✓!

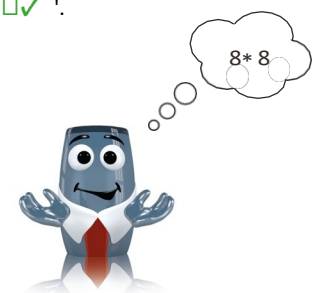

Once the code has been entered correctly, the configuration window appears.

Here you can enter the CAN bus network, if available.

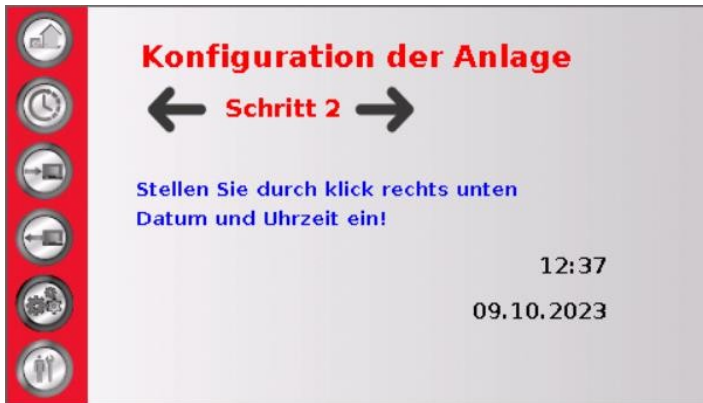

The time and date can be set here.



+ or - (change the value by +/- 1 hour)

++ or -- (change the value by +/- 10 hours)

1/2/3/4...
Direct entry of values

← Undo input by 1 character

Without change, return to red X.

Apply change and return green ✓.



Here you can register a second automatic heat generator and a second heating circuit, if available.



Automatic heat generator 1

If the heat generator is to be controlled in a modulating manner, you must answer YES here.



Konfiguration der Anlage

← **Schritt 5** →

Beantworten Sie folgende Fragen!

Ist eine Solarthermieanlage vorhanden? **Ja**

NEIN: Schritt 6 wird übersprungen.

Solar thermal

If solar thermal energy is available, answer YES here.



Konfiguration der Anlage

← **Schritt 6** →

Beantworten Sie folgende Fragen!

Solarregelung auf festen Kollektorwert? **Nein**
Bitte stellen Sie den Regelwert ein!
(Empfehlung 50-70°C) **60 °C**

Falls nicht, wird auf Sollwerte (WW, Hz) geregelt!

Collector value

The collector values can be entered here.



Konfiguration der Anlage

← **Schritt 7** →

Beantworten Sie folgende Fragen!

Soll die Heizungsanforderung über die
HK-Vorlauf-Fühler erfolgen? **Nein**

Ist der Heizkreis kühlbar? **Nein**
Ist der Heizkreis aktiv kühlbar? **Nein**
Passive Kühlung? **Ja**

Heating demand



Konfiguration der Anlage

← **Schritt 8** →

Beantworten Sie folgende Fragen!

Ist ein Holzofen mit Wärmeauskopplung
vorhanden? **Nein**

Ist eine ratiotherm WP vorhanden? **Nein**
wenn Ja, welcher Typ **0**
(1=Max-Air, 2=Max-W&S)

Ist ein Oskar Smart Energy System vorhanden? **Nein**
wenn Ja, soll als Notheizung
Netzstrom gezogen werden? **AUS**

Konfiguration der Anlage
← **Schritt 9** →

Beantworten Sie folgende Fragen!

Soll ein Warmwasser-Vorrang geregelt werden? **Nein**
JA: Die Heizkreispumpen werden zyklisch Ein und Aus geschaltet.
Die Nachladung von Warmwasser in den Speicher wird schneller erfüllt.

Konfiguration der Anlage
← **Schritt 10**

Beantworten Sie folgende Fragen!

Hiermit wird bestätigt, dass die Konfiguration ordnungsgemäß durchgeführt wurde! **Nein**

Once you have completed all configurations, you must switch to YES here.

Konfiguration der Anlage
wurde beendet.

ZUR BEDIENOBERFLÄCHE

Anlagenschema 

Zeiten und Sollwerte

Eingänge

Ausgänge

Wartung

Service

After completing and confirming the configuration, you will be taken to the controller overview.



The **ECO function** ensures that the heat demand is primarily covered by the solar system. Early reheating is avoided. Therefore, the room temperature may temporarily drop when it is very cloudy. Hot water circulation is limited to pulse tapping while the ECO function is activated in order to save additional energy. The time programme is deactivated during this time.

Offset Hz Oskar = -5°C Offset

WW-Oskar = -5°C

-5°C means that the actual programmed Hz or WW value may fall below this temperature by this amount. Settings up to -15°C are possible.



Deviations can be programmed here outside the standard programmed heating and hot water times.

Party - exceeds the programmed switch-off times.

Holiday - blocks the programmed times and temperatures for heating, hot water and circulation.

Standby - heating and hot water off - frost protection active.

Holidays - exceeds the programmed shutdown times.

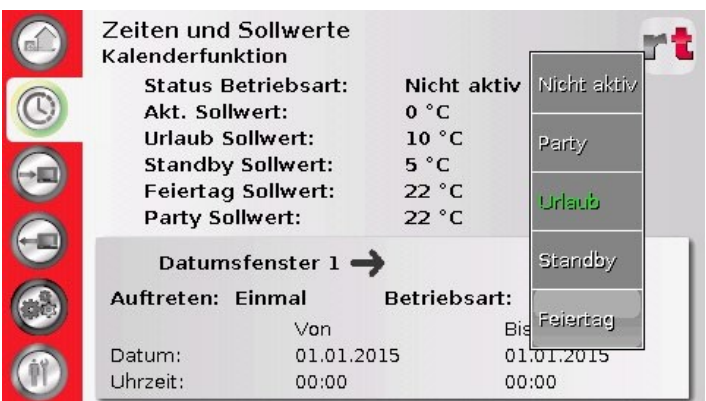

8.3 INPUTS

Eingänge		
Seite 1/4 →		
S1	T.Außen	30 °C
S2	T.Speicher oben 1	50 °C
S3	T.Speicher oben 2	41 °C
S4	T.Speicher mitte	39 °C
S5	T.Speicher unten	31 °C
S6	unbenutzt	75 °C

Informative display of current system inputs available on 4 pages.

Eingänge		
← Seite 2/4 →		
S7	T.Kollektor	75 °C
S8	T.WT Solar	56 °C
S9	T.WE 1	30 °C
S10	T.Holzofen	46 °C
S11	T.Heizkreis VL 1	35 °C
S12	T.Heizkreis VL 2	0 °C

Eingänge		
← Seite 3/4 →		
S13	T.Warmwasser	28 °C
S14	T.Zirkulation RL	43 °C
S15	Durchfluss Kaltwasser	33 l/h
S16	unbenutzt	AUS
DL	T.Solar RL	0 °C
DL	Durchfluss Solar	0 °C

Eingänge		
← Seite 4/4		
K32 S1	nicht vorhanden	
K32 S2	nicht vorhanden	
K32 S3	nicht vorhanden	

8.4 OUTPUT



Ausgänge			
Seite 1/3 →			
A1/2	Mischer-Heizkreis 1	0 %	Auto
A3	Heizkreispumpe 1	Auto	AUS
A4	Ventil-Warmwasser	Auto	AUS
A5	Anf. WE pot. frei	Auto	AUS
A6	Ladepumpe-Speicher 1	Auto	AUS
A7	Zirkulationspumpe	Auto	AUS

Informative display of the current system outputs available on 3 pages.



Ausgänge			
Seite 1/3 →			
A1/2	Mischer-Heizkreis 1	100 %	Auto
A3	Heizkreispumpe 1	Auto	EIN
A4	Ventil-Warmwasser	Hand/AUS	AUS
A5	Anf. WE pot. frei	Hand/EIN	AUS
A6	Ladepumpe-Speicher 1	Hand/EIN	AUS
A7	Zirkulationspumpe	Auto	AUS

Setting options via pop-up window



Ausgänge			
← Seite 2/3 →			
A8/9	Mischer-Heizkreis 2	100 %	Auto
A10	Heizkreispumpe 2	EIN	Auto
A11	unbenutzt	AUS	Auto
A12	Ladepumpe-Speicher 2	AUS	Auto
A13	0-10V WE 1	0 V	AUS
A14	PWM P.Solar 1	70 %	EIN

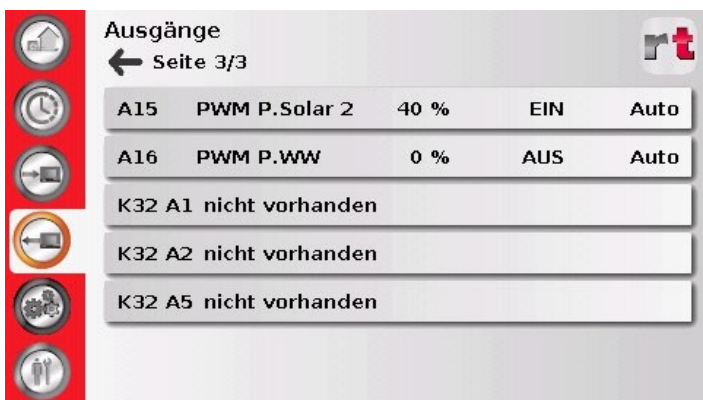

Ausgänge			
← Seite 3/3			
A15	PWM P.Solar 2	40 %	EIN
A16	PWM P.WW	0 %	AUS
K32 A1 nicht vorhanden			
K32 A2 nicht vorhanden			
K32 A5 nicht vorhanden			

8.5 MAINTENANCE



Boiler start

Pressing the boiler start symbol activates the chimney sweep function to determine the calorific values.

The maximum running time is 20 minutes. After this, the control system returns to automatic mode.



Boiler Stop

Pressing the boiler stop symbol terminates the chimney sweep function prematurely.

8.6 SERVICE



The Service menu is the interface between experts only and basic system functionality.

In this menu, the expert can make fundamental changes to the system.

Changes should always be made with care and documented.



Heating circuit and cooling circuits have identical settings.



- Flow temperature – informative display
- Outside temperature – informative display
- Operation - selectable via pop-up window
- Heating circuit pump – informative display
- Frost protection selectable via T-Outdoor and T-Room



- Room influence – with connected room thermostat
- Operating increase – for underfloor heating for faster heating up after any night-time reduction
- Max and min flow – temperature limits
- Level *
- Required heating flow at +10°C outside temperature
- Required heating flow rate at an outside temperature of -20°C

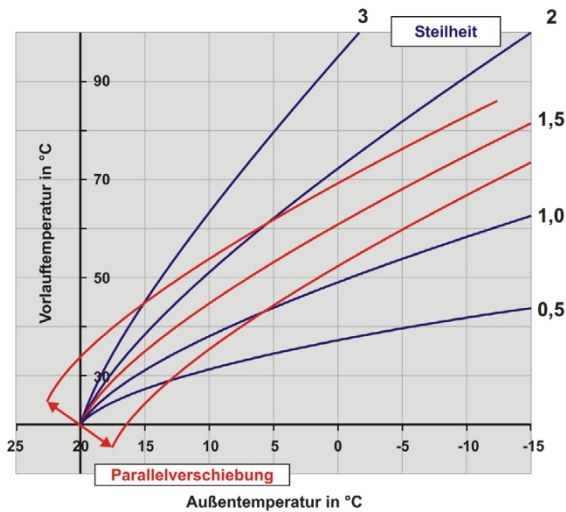

* The height (level) of the curve can be used to adjust the output of the heating system in general. This allows system owners to raise or lower the flow temperature evenly. The following applies: if the heating surfaces emit a lot of heat throughout the year, the heating curve can be shifted downwards. If, on the other hand, it is always a little too cold, the curve should be adjusted upwards. This increases heating costs, but also means that the boiler emits more heat.



Heating demand control
Heating demand via VL sensor and mixer

- Options No/Yes

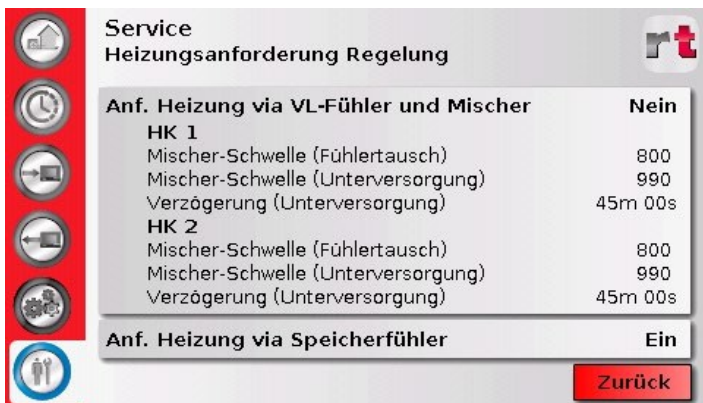

HK1 and HK2 identical setting options when YES is selected

- Mixer threshold (sensor replacement)
- Mixer threshold (under-supply)
- Delay (under-supply) Start heating via

storage tank sensor

8.7 SERVICE SUMMER/WINTER OPERATION

Service
Heizkreis 2 - Setup Abschaltbedingungen

Abschalten, wenn T.Soll VL < Min.	Nein
Abschalten, wenn T.Ist VL > Max.	Nein
Abschalten, wenn T.Außen > Max.	Ja
T.Außen Max	20.0 °C
wenn T.Außen - Diff. Ein	-2.0 K
wenn T.Außen - Diff. Aus	0.0 K
Abschalten, wenn T.Außen > Max. (Absenk)	Ja
T.Außen Max	10.0 °C
wenn T.Außen - Diff. Ein	-2.0 K
wenn T.Außen - Diff. Aus	0.0 K

Zurück

- Switch off when T-setpoint < min.:
- Switch off when T-setpoint > Max.:

Switch off when T-outdoor > Max.:
Defines the switch-off conditions in normal operation.

- T-outdoor-max is the temperature up to which heating should take place (factory setting 20°C).
- Diff. On -2.0K determines at which outside temperature (here 18°C) heating is resumed.
- Diff. Off 0.0K determines at which outside temperature (here 20°C) heating operation is stopped again.

Service
Heizkreis 2 - Setup Abschaltbedingungen

Abschalten, wenn T.Soll VL < Min.	Nein
Abschalten, wenn T.Ist VL > Max.	Nein
Abschalten, wenn T.Außen > Max.	Ja
T.Außen Max	20.0 °C
wenn T.Außen - Diff. Ein	-2.0 K
wenn T.Außen - Diff. Aus	0.0 K
Abschalten, wenn T.Außen > Max. (Absenk)	Ja
T.Außen Max	10.0 °C
wenn T.Außen - Diff. Ein	-2.0 K
wenn T.Außen - Diff. Aus	0.0 K

Zurück

Switch off when T-Outdoor > Max. (Reduction):
Defines the switch-off conditions in reduced mode.

- Outdoor temp. max. is the temperature up to which heating operation should take place (factory setting 10°C).
- Diff. On -2.0K determines at which outside temperature (here 8°C) heating is resumed.
- Diff. Off 0.0K determines at which outside temperature (here 10°C) heating operation is stopped again.

Service
Heizkreis 2 - Setup Abschaltbedingungen

Abschalten, wenn T.Soll VL < Min.	Nein
Abschalten, wenn T.Ist VL > Max.	Nein
Abschalten, wenn T.Außen > Max.	Ja
T.Außen Max	20.0 °C
wenn T.Außen - Diff. Ein	-2.0 K
wenn T.Außen - Diff. Aus	0.0 K
Abschalten, wenn T.Außen > Max. (Absenk)	Ja
T.Außen Max	10.0 °C
wenn T.Außen - Diff. Ein	-2.0 K
wenn T.Außen - Diff. Aus	0.0 K

Zurück

8.8 SCREED HEATING

Floor heating programme in standard mode via heating circuit 1

Service Estrichprogramm Setup

Taktzeit der Stufen 24h 00m 00s

Stufe 1	25 °C	St 11	40 °C	St 21	0 °C
Stufe 2	30 °C	St 12	35 °C	St 22	0 °C
Stufe 3	35 °C	St 13	30 °C	St 23	0 °C
St 4	40 °C	St 14	25 °C	St 24	0 °C
St 5	45 °C	St 15	0 °C	St 25	0 °C
St 6	50 °C	St 16	0 °C	St 26	0 °C
St 7	50 °C	St 17	0 °C	St 27	0 °C
St 8	50 °C	St 18	0 °C	St 28	0 °C
St 9	50 °C	St 19	0 °C		
St 10	45 °C	St 20	0 °C		

Service Estrichprogramm Setup

Taktzeit der Stufen 24h 00m 00s

Stufe 1	25 °C	St 11	40 °C	St 21	0 °C
Stufe 2	30 °C	St 12	35 °C	St 22	0 °C
Stufe 3	35 °C	St 13	30 °C	St 23	0 °C
St 4	40 °C	St 14	25 °C	St 24	0 °C
St 5	45 °C	St 15	0 °C	St 25	0 °C
St 6	50 °C	St 16	0 °C	St 26	0 °C
St 7	50 °C	St 17	0 °C	St 27	0 °C
St 8	50 °C	St 18	0 °C	St 28	0 °C
St 9	50 °C	St 19	0 °C		
St 10	45 °C	St 20	0 °C		

Profil starten Akt. Stufe: 0 **Zurück**

Change the temperatures of the heating circuit per day after consulting your screed floor specialist (screed layer). First, set the cycle times for the stages. Then select the days individually and enter the required temperatures.

There are 28 days available.

Start the profile

The profile now runs automatically, but can be interrupted prematurely and restarted by pressing the button again. In the event of a power failure, the programme will continue where it was interrupted.



Please note that in conjunction with a heat pump, screed heating may not be possible in cold outside temperatures if no additional heat sources are available.

8.9 CHARGING PUMPS

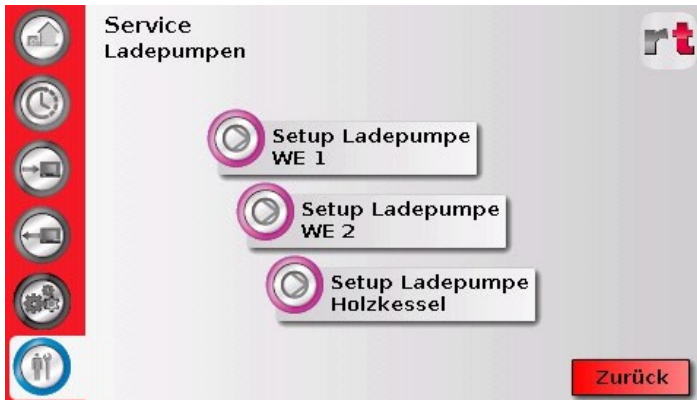

Charge pump menu



Charge pump automatic heat generator 1

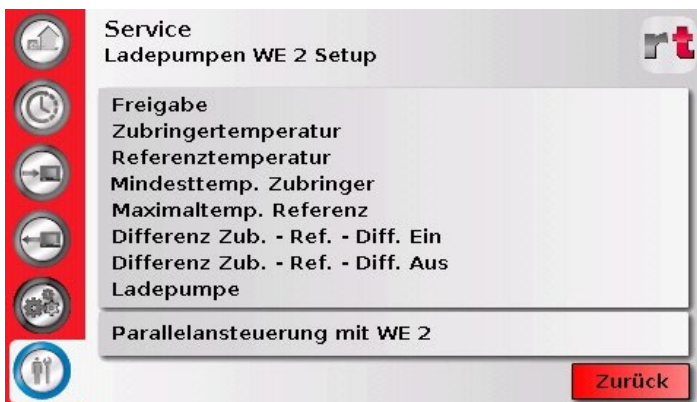

Charging pump for automatic heat generator 2 (optional with separate accessory RSM)

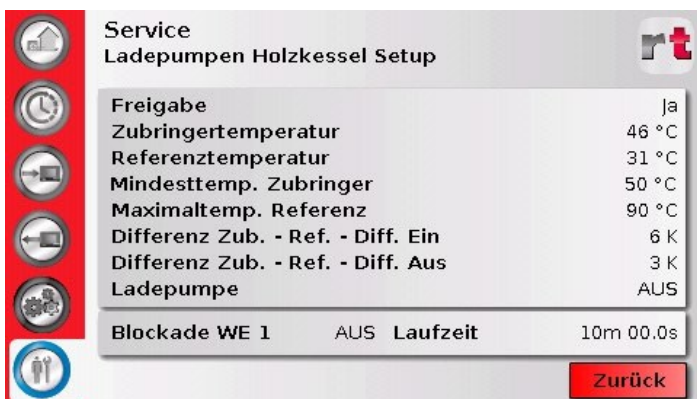

Charging pump for manual heat generator (wood gasifier)

8.10 SOLAR THERMAL



Solar thermal energy menu



Solar primary

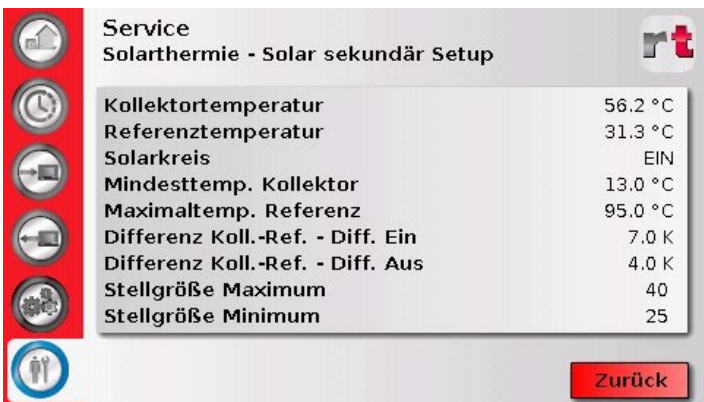

Solar secondary

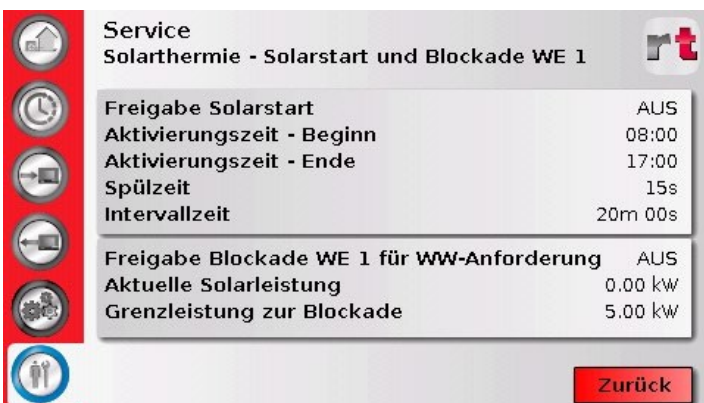

Solar start + WE1 block

8.11 HEAT GENERATION

Service Wärmerezeuger Regelung

WE 2 vorhanden	Ja
Außentemperatur	3 °C
Bivalenzpunkt	3 °C
Diff. Ein	3 K
Diff. Aus	-1 K

Kaskadierung WE 1 und WE 2: Ja
Schaltung 2.WE bivalenzabhängig: nach 2h 00m 00s

WE 1 und WE 2 **Holzofen**

Zurück

Service WE Regelung - WE 1 und WE 2

	WE 1	WE 2
WW Anforderung		
Mindestlaufzeit	0.0s	
Status Mindestlaufzeit	AUS	
Hz Anforderung		
Mindestlaufzeit	0s	
Abschalttemp. Diff Aus	6 K	
Brennermodulation	Ja	

Zurück

Service WE Regelung - WE 1 und WE 2

	WE 1	WE 2
WW Anforderung		
Mindestlaufzeit	0.0s	
Status Mindestlaufzeit	AUS	
Hz Anforderung		
Mindestlaufzeit	0s	
Abschalttemp. Diff Aus	6 K	
Brennermodulation	Ja	

Zurück

Service WE Regelung - Holzofen

Blockade WE durch WRG aus Holzofen	
Freigabe	AUS
Status Blockade	AUS
Blockadezeit	10m 00.0s

Zurück

Bivalence point can be selected manually, varies depending on the building and heat generator. The bivalence point depends on the outside temperature. Once the selected setpoint is undershot, the second heat generator is activated.

Cascading YES means that WE2 is switched on when the bivalence point is reached. Both WE are active.

For heat generators that are not intended to be switched on and off frequently (e.g. pellet boilers), a minimum running time can be set here. However, to prevent excessive reheating in heating circuit operation, a switch-off temperature Diff Off can be set here, which causes premature switch-off if the programmed heating curve value is exceeded by this difference.

The burner modulation is defined in the factory setting via a 0-10 volt signal.

Control is adjusted according to the temperature or output of the heat generator.

Individual adjustments can be made by factory technicians.

To prevent the automatic heat generator from switching on at the same time as the wood boiler is in operation (e.g. during heating), this can be prevented by blocking it.

To do this, set the release to ON and specify a time window (depending on the output of the wood boiler) that gives the wood boiler time to generate usable temperatures in the storage tank.



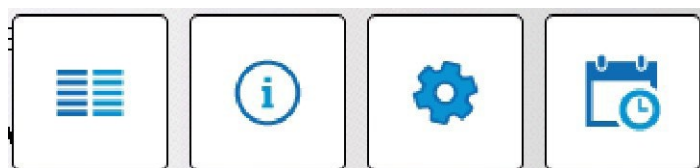

If this is not achieved within the set time window, the automatic WE is activated to maintain comfort.

9. DATA MANAGEMENT

9.1 OVERVIEW WINDOW



Press and hold the display for at least 3 seconds to bring up another selection menu for the overall overview, version, basic settings, date and time.

-  =General overview
-  =Version overview
-  =Basic settings
-  =Date, time, location settings

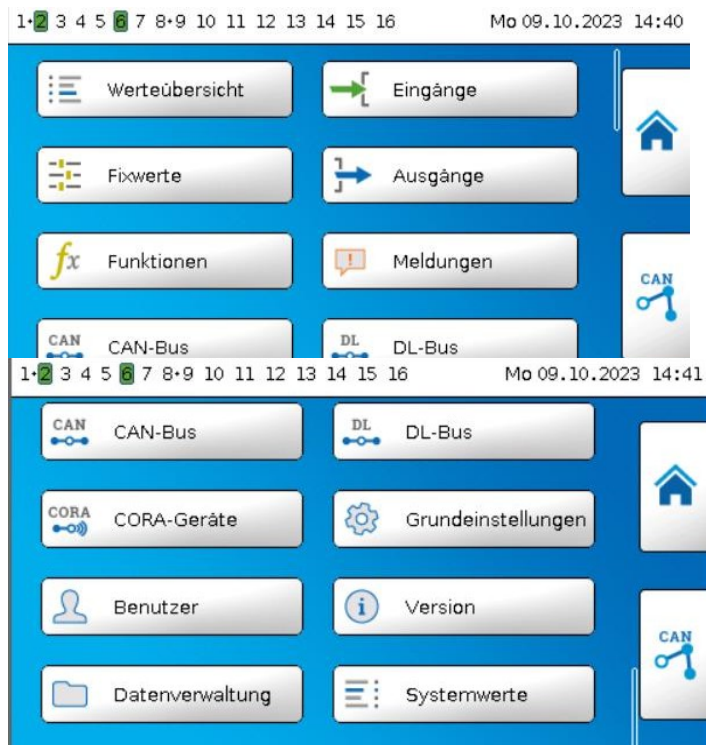

The overall overview spans two display fields.

By moving the display upwards, the second window appears with the data management symbol at the bottom right.

Pressing the data management icon takes you to the sub-level of data management.

9.2 FUNCTION DATA

1-2 3 4 5 6 7 8-9 10 11 12 13 14 15 16 Di 16.06.2020 15:46



Function data is the standard programming currently available on the controller according to the system diagram in this technical document.

Adjustments are possible on request at an additional cost.

- Load = Load data from the SD card
- Save = Save data to the SD card
- Total reset deletes the function modules, the parameterisation of all inputs and outputs, bus inputs and outputs, fixed values and system values.

1-2 3 4 5 6 7 8-9 10 11 12 13 14 15 16 Di 16.06.2020 15:48



Here you can load the function data stored on the SD card onto the controller or save individually set data from the controller to the SD card.

Selecting a yellow folder displays a selection of the various programming options on the SD card.

1-2 3 4 5 6 7 8-9 10 11 12 13 14 15 16 Di 16.06.2020 16:03

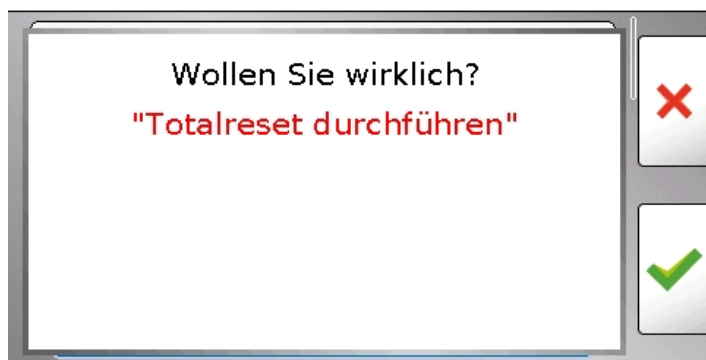

TOTAL RESET



ATTENTION!

Deletes the function modules, the parameterisation of all inputs and outputs, bus inputs and outputs, fixed and system values.

1-2 3 4 5 6 7 8-9 10 11 12 13 14 15 16 Di 16.06.2020 16:05

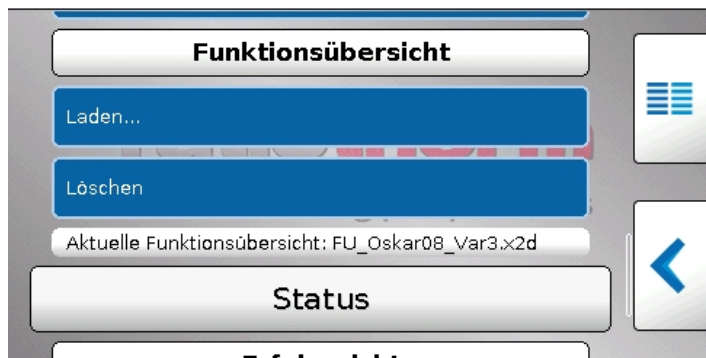

The function overview is the graphical interface (hydraulic diagram) in X2D format.

1-2 3 4 5 6 7 8-9 10 11 12 13 14 15 16 Di 16.06.2020 16:05

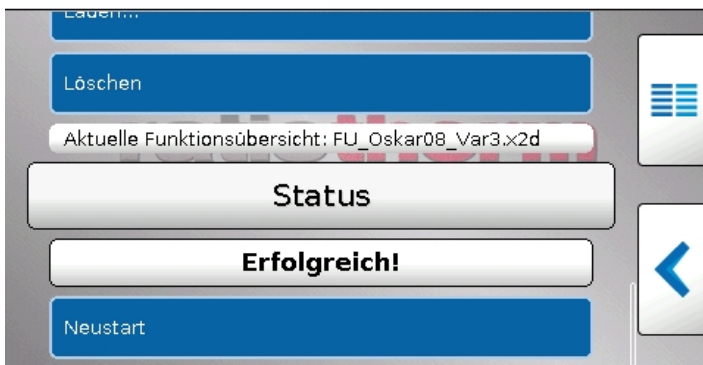

After the data has been loaded, the status is displayed.

Pressing the "Restart" button resets the controller and restarts it with the most recently uploaded data.

9.3 BASIC SETTINGS



Press and hold the display for at least 3 seconds to bring up another selection menu.

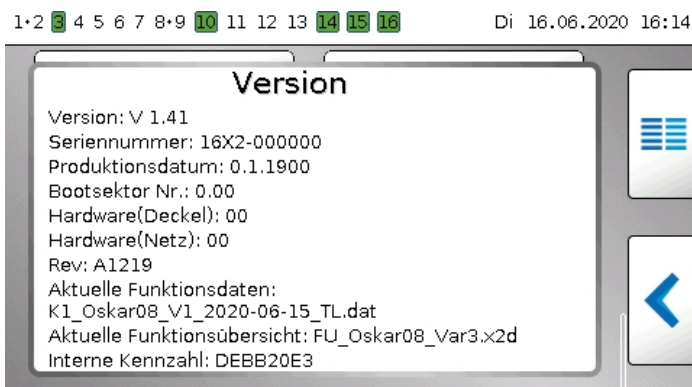

For all technical enquiries, it is important to provide this version number, as otherwise it will not be possible to provide correct information.

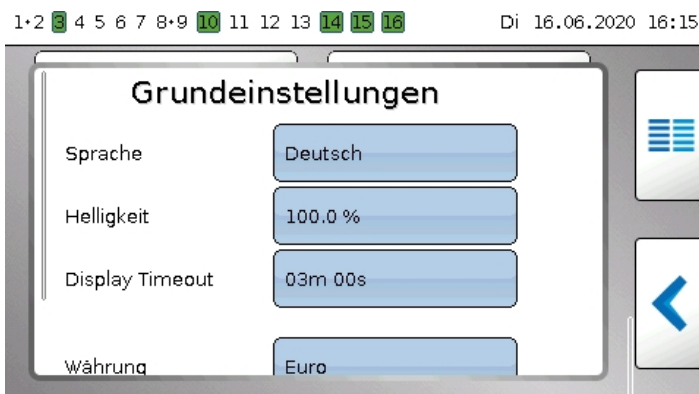

- Setting the country language
- Setting the display brightness
- Display turns off after this set time

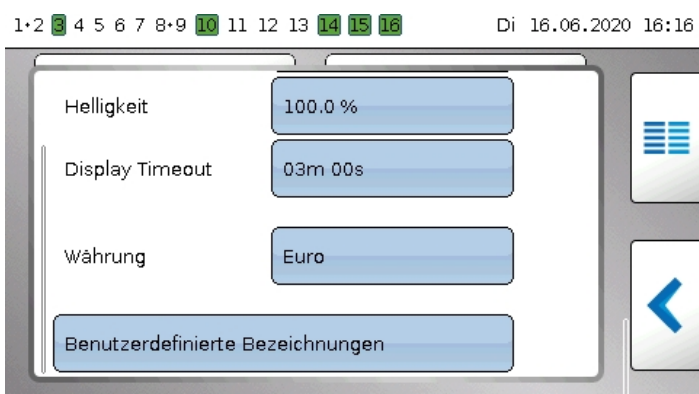

Once the data has been entered correctly, location-based data is displayed:

Sunrise, sunset, sun elevation, sun direction (measured from the north)

10. CONTROLLER ACCESSORIES

10.1 C.M.I INSTALLATION

The C.M.I is an interface for convenient system monitoring, remote control, data logging and visualisation of all controllers and devices with DL or CAN bus.

Interfaces: CAN bus, DL bus, Ethernet, SD card

Remote maintenance of CAN bus devices; Function data management for CAN bus devices; Operating system management for CAN bus devices;

System visualisation via PC, smartphone or tablet; modification of CAN bus device parameters; data logging via CAN bus or DL bus; event-driven notification by e-mail; top-hat rail or wall mounting;

Plug & Play solution via server; slot for GSM module MDC-GSM; connection option to Modbus TCP



WNA router

For an Internet connection, the C.M.I must be connected to the on-site router (e.g. Fritz box) using a LAN cable.

If this is not possible, the WNA router can be connected to the C.M.I via a LAN cable.

This WNA router then sends the corresponding signals to the Internet router.

However, it can also be connected to the Internet via a UMTS stick.

Plug the C.M.I. into the designated circuit board socket and make the following connections:

1. Connect the LAN cable to the router (e.g. Fritz box) or WNA router
2. Connection to the CAN bus
3. Power supply via the controller's motherboard

With the C.M.I app from ratiotherm, you can quickly and easily access your C.M.I via the Technische Alternative GmbH web portal.

You can conveniently access your controller via an app and monitor it from anywhere in the world using your smart device, allowing you to adjust the settings.



10.2 C.M.I ONLINE CONNECTION

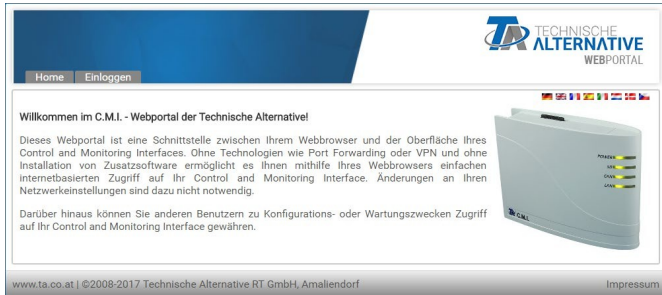
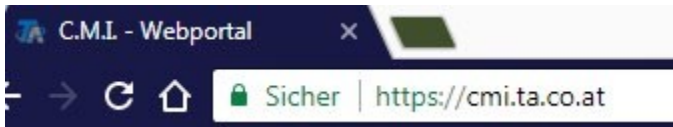

Persönliche Daten

Anrede *
Frau

Vorname/Nachname *
[] []

Firmenname
[]

Straße/Hausnummer *
[] []

Postleitzahl/Stadt *
[] []

Land *
Austria

Benutzerdaten

Benutzername *
[] ⓘ

E-Mail *
[]

E-Mail wiederholen *
[]

Passwort *
[]

Passwort wiederholen *
[]

Hiermit bestätige ich die [Nutzungsbedingungen](#) *

* ist ein Pflichtfeld.

Registrieren

IP address

An IP address is required for access.

In a network with a DHCP server (standard), the network settings are determined automatically.

In a network without a DHCP server, a direct connection to the Windows PC must be established. DHCP must be enabled on the PC. This allows the PC and the C.M.I. to automatically obtain an IP address.

This process may take longer than 1 minute!

Welcome to the C.M.I. web portal from Technische Alternative!

This website is an interface between your web browser and the user interface of your Control and Monitoring Interface. Without technologies such as port forwarding or VPN and without installing additional software, it allows you to easily access your Control and Monitoring Interface via the internet using your web browser. No changes to your network settings are necessary.

In addition, you can grant other users access to your Control and Monitoring Interface for configuration or maintenance purposes.

If you do not yet have your own account, you must register.

Click on the "Register" button.

- Now enter your personal details.

- Then enter your freely selectable user data and make a note of it.
- Then confirm your entries by clicking on the "Register" button.
- After submitting your registration, you will receive an email with a link to activate your account, which you should confirm with a click of the mouse.



- Now enter the username you chose when you registered.
- Add your personal password.
- Then click on the "Log in" button.



Once you have logged in, your personal account area will open.

Clicking on "Add C.M.I." will open a new window.



The C.M.I comes with a serial number and a key, which are stuck on the back.



The serial number, in this case CMI012345, and the key, in this case 040a7d3f, must be entered in the corresponding input fields.

Enter the key without spaces!

After refreshing the internet page, the C.M.I. will appear in the "My C.M.I.s" list.

10.3 WNA ONLINE CONNECTION



The following parts are included with the device:

- Wireless router WNA (TL-MR3020)
- Power supply
- USB cable
- Ethernet LAN cable
- A CD containing: Operating instructions (English)
- Installation guide (German)

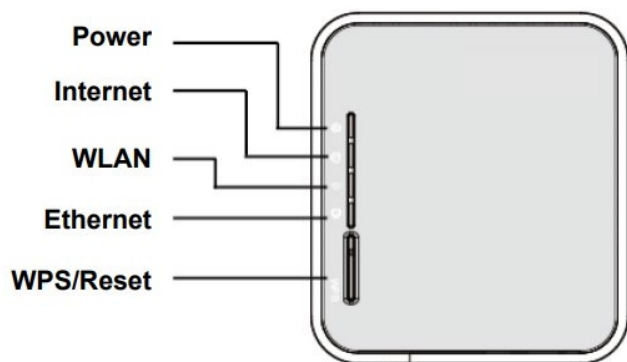

LED power	ON	The router receives electrical power
	OFF	The router is switched off
LED Internet	ON	Internet connection - no data transfer
	FLASHING	Internet connection - data transmission
	OFF	Internet connection interrupted
LED Wi-Fi	ON	WLAN interface activated
	FLASHING	WLAN interface - data transmission
	OFF	WLAN interface deactivated
LED Ethernet	ON	Port connection available
	FLASHING	Port connection - data transmission
	OFF	Port connection not established

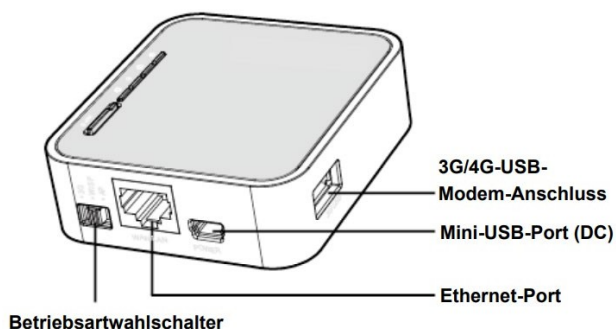

- 3G/4G USB port: Connection for the USB modem.
- Mini USB port: Connection for power supply.
- Ethernet port: This port is used as a LAN connection.
- Operating mode selector switch: Selection of router modes. If the operating mode is changed during operation, the router will restart.

The router's data is located on a sticker on the side of the router:

MAC address, key, SSID and default settings: IP address, username, password.

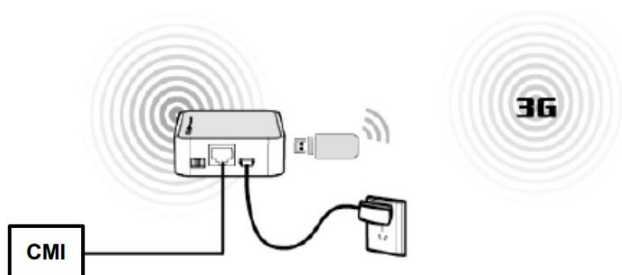

As a 3G/4G router (with 3G/4G modem/card), this router can connect to a 3G mobile network and provide its Internet connectivity under its own WLAN SSID.

11. PROBLEM SOLVING

11.1 PROBLEM SOLUTIONS



No indication of a power failure. Therefore, first check the power supply to the controller and then the device fuse (20x5mm glass tube fuse, 6.3A fast-acting), which protects the device against short circuits and overcurrent due to ground faults. The device fuse is located on the rear of the controller behind a screw connection.

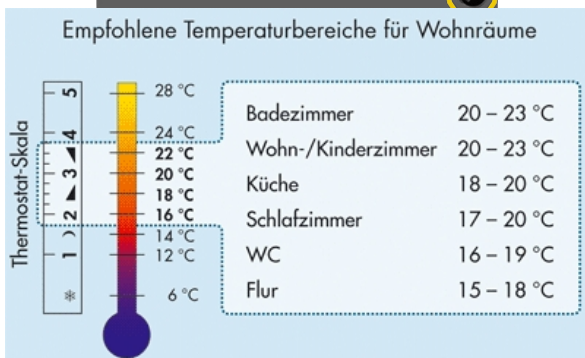

The room temperature is incorrect.

- Are the date and time set correctly?
- Is the controller switched off?
Check the fuse in the electrical distribution board, heating emergency switch or device switch.
- Burner malfunction?
- Are the radiator valves stuck or set too low?
- Are the controller settings correct? Check the room set temperatures, heating curves and sensors.

Hot water temperature is incorrect

- Are the date and time set correctly?
- Is the controller switched off?
- Are the controller settings correct?
- Burner malfunction?
- Air in the storage tank?
- Heat exchanger calcified?
- Hydraulic problems on site (mixer tap, non-return valve, pressure reducer, etc.)



Hot water temperature fluctuates after a short time

- Check the temperature control in the storage tank; it should be approx. 10 degrees higher than the desired outlet temperature.
- Check the immersion depth of the hot water sensors in the storage tank to ensure that sufficient hot water is stored.
- Air in the storage tank? - Vent the storage tank
- Check the hot water settings on the controller.
- Check the hot water outlet temperature using an ultra-fast sensor.
 - If OK, the problem is on site.
- Set the pump in the controller to continuous operation at 100% power.
 - If OK, check the controller output – is the controller defective?
- Open the mixing valve fully.
 - If OK, heat exchanger possibly calcified? Or problem on site
- Hydraulic problems on site
 - Check the non-return valve of the circulation pump
 - Shut off and check mixing valves individually
 - If available, check water-saving fittings for pressure flow rate





- Message 9999.9 = Sensor interruption

Check all connection points for interruptions. If the message is still displayed, the sensor is defective.



- Message -9999.9 = Sensor short circuit

Check all terminals for contact bridges. If the message is still displayed, the sensor is defective.

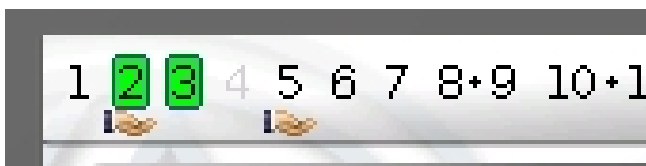

- Output does not switch on or off despite request Manual switch on the controller housing activated.

Output in the controller permanently switched on in **MANUAL mode** (hand symbol) (green background) (without background) permanently switched off.



Burner runs at night despite request

- Safety temperature limiter STB triggered?
- Burner fault on site?
- Check wiring – were "W" and "S" used?
- Check potential-free output with ohmmeter.
- Check output with potential using a voltage meter.
- Check the connection between the controller and the burner.

The indicator light can display various statuses:

- **RED steady light:** The controller is booting up (=start-up routine after switching on, a reset or update) or displaying a message that has not yet been deleted.
- **ORANGE steady light:** Hardware initialisation after booting.
- **GREEN steady light:** normal operation of the controller.
- **GREEN flashing:** after hardware initialisation, the controller waits approx. 30 seconds to receive all the information necessary for operation (sensor values, network inputs).

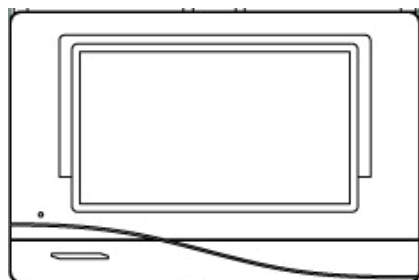

12. APPENDIX

12.1 PUMP WILO PARA STG 15/8-75



Technical	
Connection voltage	1~230V +10%/-15%, 50/60Hz
Protection class	IPX4D
Energy efficiency EEI	see type plate
Medium temperatures at max. ambient temperature	-20°C to +95°C (heating/GT) -10°C to +110°C (ST)
Ambient temperature	0°C to +70°C
Max. operating pressure	10 bar (1,000 kPa)
Minimum inlet pressure at +95°C/+110°C	0.5 bar/1.0 bar (50 kPa/100 kPa)

Indicator lights (LEDs)	
<ul style="list-style-type: none"> LED lights up green during normal operation and flashes in standby mode LED lights up/flashes red in the event of a fault 	
Indicator for the selected control mode PWM, Δp-c and constant speed	
Display of the selected characteristic curve (I, II, III) within the control mode	
Control buttons	
Press <ul style="list-style-type: none"> Select control mode Select characteristic curve (I, II, III) within the control mode 	
Press and hold <ul style="list-style-type: none"> Activate venting function (press for 3 seconds) Activate manual restart (press for 5 seconds) Lock/unlock button (press for 8 seconds) 	

12.2 CONTROL MODES AND FUNCTIONS

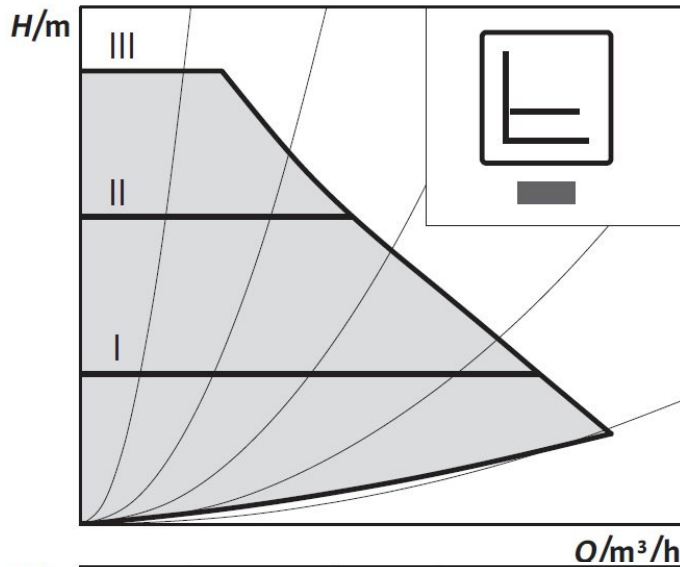

Constant differential pressure $\Delta p-c$ (I, II, III)

Recommended for underfloor heating systems, large-diameter pipes, or any application without variable pipe network characteristic curve (e.g. storage tank charging pumps), as well as single-pipe heating systems with radiators. The control keeps the set delivery head constant regardless of the volume flow delivered. Three predefined characteristic curves (I, II, III) to choose from.

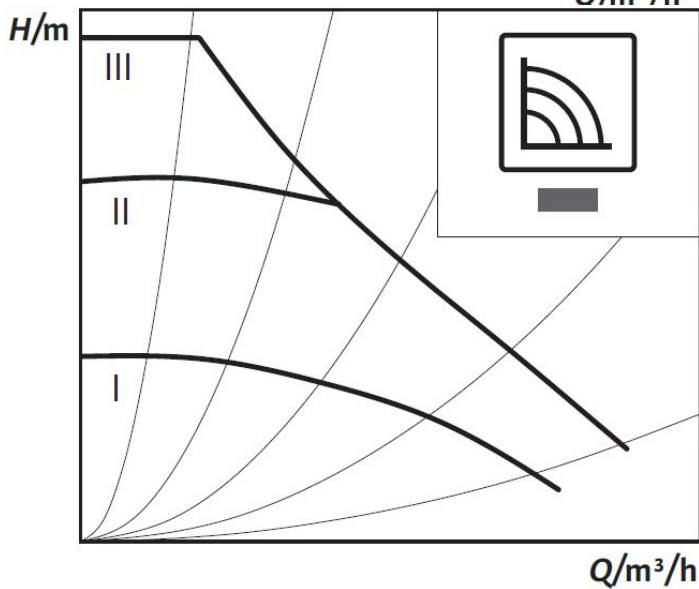

Constant speed (I, II, III)

Recommended for systems with unchanging system resistance that require a constant volume flow. The pump runs at three predefined fixed speed levels (I, II, III).

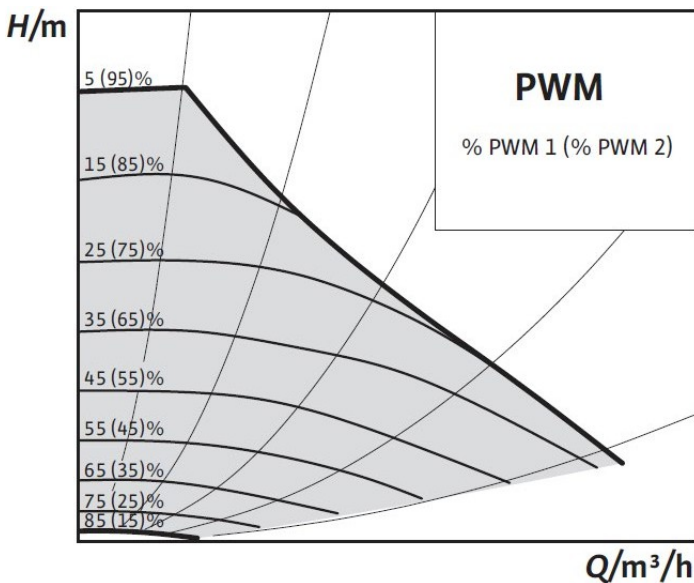

External control via PWM signal

The required setpoint/actual value comparison is performed by the ratiotherm central controller for control purposes. A PWM signal is fed to the pump as a control variable via a separate cable with plug (pulse width modulation). The PWM signal generator sends a periodic sequence of pulses (the duty cycle) to the pump in accordance with DIN IEC 60469-1.

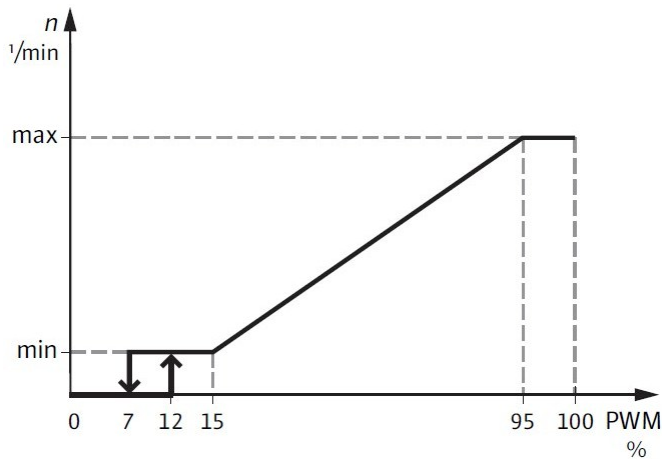

PWM 2 Modbus:

In iPWM 2 Modbus, the pump speed is controlled depending on the PWM input signal. Behaviour in the event of a cable break: If the signal cable is disconnected from the pump, e.g. due to a cable break, the pump stops.

PWM signal input (%)

- 0 - 7: Pump stops (standby)
- 7 - 15: Pump runs at minimum speed (operation)
- 12 - 15: Pump runs at minimum speed (start-up)
- 15 - 95: The speed of the pump increases linearly from n_{min} to n_{max}
- > 95: Pump runs at maximum speed

Δp -c (constant)

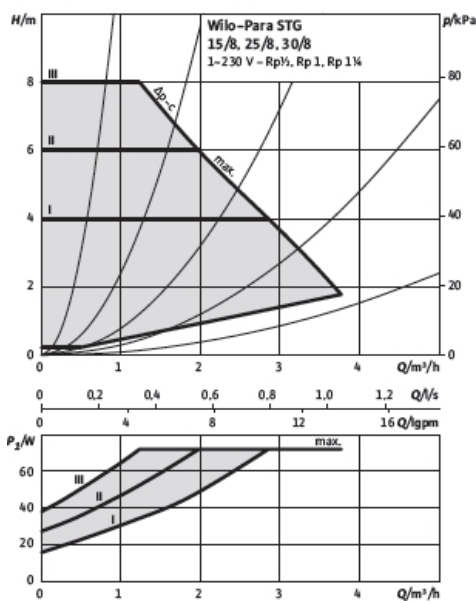

Constant speed I, II, III

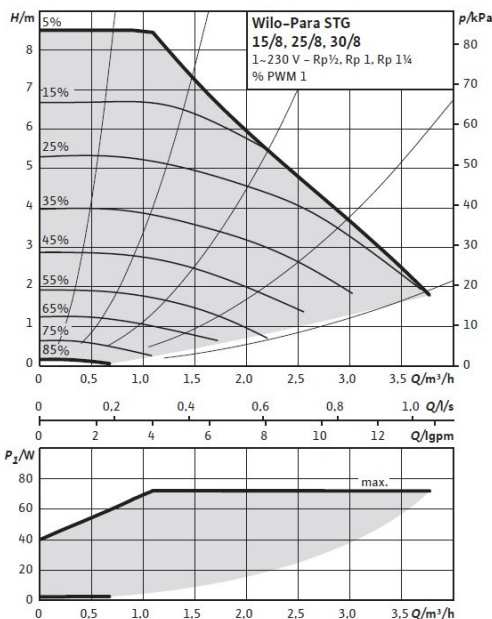
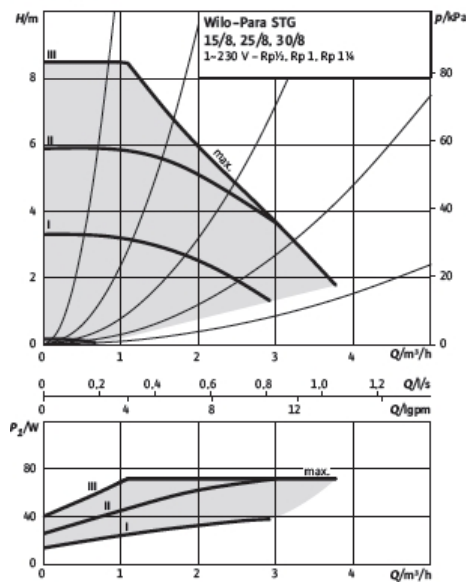

Ventilation

The venting function is activated by pressing and holding (3 seconds) the control button and automatically vents the pump. The heating system is not vented during this process.

Manual restart

A manual restart is activated by pressing and holding (5 seconds) the control button and unblocks the pump if necessary (e.g. after a long period of inactivity during the summer).

Key lock

The key lock is activated by pressing and holding (8 seconds) the control button and locks the settings on the pump. It protects against unwanted or unauthorised adjustment of the pump.

12.3 EMERGENCY OPERATION OF THE PUMP



Symbol for constant speed

Pump manual mode or in the event of a PWM signal fault

Press the green control button.
Display switches to different control modes.

Press the green control button several times to set the operating mode to constant speed.
Press again to set the pump speed in 3 stages.

For TWK, always set to level III (3)!

12.4 VRG 138 ELECTRIC MIXER



<http://www.esbe.eu/global/en/products/rotary-valves>

VRG 138 are 3-way valves, suitable for mixing or zone operation. The valves are made of high-quality brass and can therefore be used in heating and cooling applications.



Technical data	
Ambient temperature	-5°C to +55°C
Temperature range, flow sensor	+5°C to 95°C
Protection class	IP41 (protection class: II)
Power supply	230V, 230V ±10% VAC, 50Hz
Torque	6 Nm
Running time at max. speed	30
Weight	0.4 kg

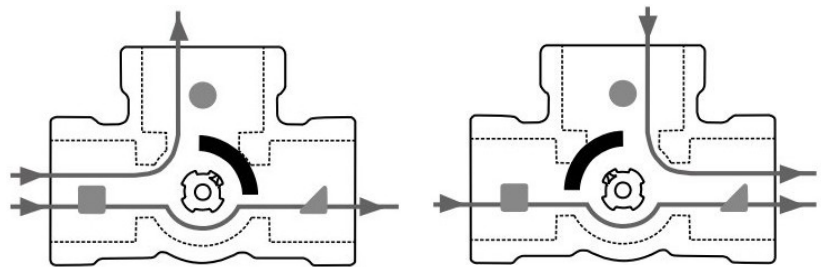

Mixing

Distribution

The notch indicates the chick position

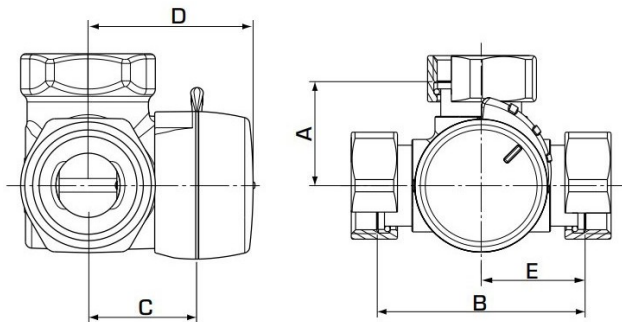

A	B	C	D	E
36	72	32	50	36

13. MAINTENANCE



WARNING

Improper handling

Improper handling of the appliance can result in serious injury. **Never attempt to carry out maintenance and/or repairs on the appliance yourself.**

For maintenance work, commission a recognised, qualified specialist tradesman (specialist personnel) authorised by ratiotherm GmbH & Co. KG.



NOTE

Improper cleaning

The appliance surfaces may be damaged by using the wrong cleaning agents.

Please observe the following instructions.

- Do not use abrasive or cleaning agents that could damage the plastic panelling, fittings or controls.
- Do not use sprays, solvents or cleaning agents containing chlorine.
- Clean the heat pump casing with a damp cloth and a little soap.
- Avoid placing or leaning objects on or against the heat pump.



NOTE

Limescale deposits

Limescale deposits can cause the safety valve to become stuck.

Operate the safety valve of the heating system manually once a month.

Symbols on the device

In order to provide staff with important information and warnings, standardised safety symbols based on the DIN EN ISO 7010, DIN ISO 3864 and DIN ISO 7000 standards have been used. These safety symbols are:

- Clearly visible to all,
- Keep in a recognisable/legible condition and
- be replaced if necessary.

As the design of the device and the complexity of the production processes do not allow the use of persons with disabilities (e.g. with visual impairments) for safety reasons, the manufacturer has decided not to affix tactile symbols. The requirements for personnel and the technical qualifications required to operate the device are described in chapter "2.3 Target groups" on page 6.

14. DECOMMISSIONING

When the heat pump is taken out of service, the device may only be dismantled by qualified personnel. Hazardous materials and waste must be disposed of properly. When dismantling the heat pump, observe the instructions at the beginning of the technical documentation and the safety instructions listed below.



DANGER

Fatal electric shock

There is a risk of fatal electric shock from electrical equipment.

Disconnect the device from the power supply before taking it out of service/dismantling it.

Secure the device against being switched back on.

14.1 TEMPORARY DECOMMISSIONING



NOTE

Improper decommissioning

Improper decommissioning of the device can result in damage to components and impaired functionality.

Switch off the device at the main switch.

Please note the following information:

- Frost may cause damage to the appliance.
- Water freezes at outdoor temperatures below 0 °C.
- Decommissioning without draining the heating circuit is only permitted at temperatures above 0 °C.

14.2 FINAL DECOMMISSIONING AND DISPOSAL

Only a specialist company may carry out final decommissioning/disposal. Environmental requirements regarding the recovery, reuse and disposal of operating materials and components in accordance with current standards must be observed.



NOTE

Improper disposal

Improper disposal of the unit may result in environmental pollution and/or damage.

Dispose of electrical and electronic components and the refrigerant from the heat pump properly and in accordance with applicable local regulations.

15. EC DECLARATION OF CONFORMITY

(Declaration of Conformity)

The ratiotherm GmbH & Co.KG
Wellheimer Straße 34
D-91795 Dollnstein

confirms that the products listed below and marked accordingly:

heat accumulators, transfer stations, solar thermal collectors, heat pumps and universal/central controllers

Trade name/type:

- >
- >
- >
- > Compact drinking water station TWK-S70, S90, S100
- > Compact drinking water heater TWKK-200ZD, TWKK-300ZD and TWKK-400ZD
- > Compact solar station SOK 6-16 and SOK 16-40 SOK 40-60
- > Solar collectors RA251-4 and RA215
- > Universal/central controller rUVR1611, rZR16x2
- > MAX and GRID heat pumps

comply with the relevant essential requirements of the EC Directives.

This declaration loses its validity if the device is modified without our consent!

EEC directives:

2014/68/EU	Pressure Equipment Directive
2014/35/EU	Low Voltage Directive
2004/108/EC	Electromagnetic compatibility
2011/65/EU	RoHS Restriction of the use of certain hazardous substances

Applied standards:

DruckbehV	(Pressure Vessel Regulation)
Pressure Equipment Directive	(Pressure Equipment Directive)
TRB 500	(Technical Rules for the Pressure Vessel Ordinance)
EN60730-1: 2011	Automatic electrical control and switching devices for household use and similar applications - Part 1: General requirements EN61000-6-3:
2007	Electromagnetic compatibility (EMC) - Part 6-2:
+A1: 2011	Emissions for residential, commercial and light-industrial environments
EN61000-6-2: 2005	Electromagnetic compatibility (EMC) - Part 6-2: Generic standards - Immunity for industrial environments

Affixing of the CE marking: On packaging, operating instructions and type plate

Dollnstein, 1 April 2009 Alexander

Weidinger

You can find us here



ratiotherm

Smart Energy Systems

ratiotherm GmbH & Co. KG Wellheimer
Straße 34
91795 Dollnstein

Direct contact:
T +49 (0) 8422.9977-0
info@ratiotherm.de
www.ratiotherm.de

